

Diaphragm valve T4 with pneumatic actuating drive



Symbol photo



Symbol photo

This document does not constitute a guarantee, it is for initial information purposes only. The product range is continually upgraded, the designs and types therefore only reflect the state of the art at the time of printing.
Subject to technical modifications!

General:

- Material: PVC-U, PP, PVDF
- Seal material: EPDM, FPM
PTFE / EPDM
- Dimensions: DN15 – DN50
d20 – d63
1/2" – 2"

Connector types:

- Solvent socket PVC DIN / ISO / ASTM / JIS
- Solvent spigot PVC DIN
- Fusion spigot PP / PVDF DIN
- Fusion socket PP / PVDF / PE DIN
- Backing flange PVDF DIN / ANSI
- Fix flange PVC / PP DIN / ANSI / JIS / BS
- Fix flange PP / PVDF DIN / ANSI / JIS / BS

Operating pressure: PN10

Control functions:

- NC – Normally closed
- NO – Normally open
- DA – Double acting

Features pneumatic actuating drive:

Body material: PA-GF
Control air socket: Stainless steel
Control air: Neutral gases / air
Installation position: Any, preferred
drive facing upwards

Technical features:

- Rapid opening and closing
- High flow rate
- Visual position indication
- NAMUR connector for solenoid valve

Accessories:

- Electrical position indicator
- Electropneumatic positioner
- 3/2 and 5/2 solenoid valve

Diaphragm valve T4

with pneumatic actuating drive



Dimensions:

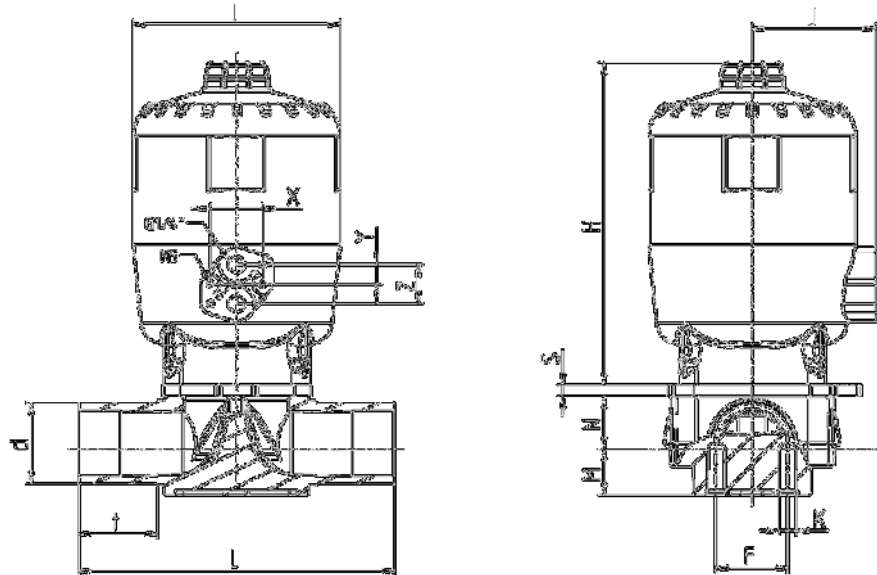

PVC-U / PP / PVDF
Connector type
 PVC solvent spigot
 PP / PVDF fusion spigot

DN	15	20	25	32	40	50
d	20	25	32	40	50	63
inch	1/2"	3/4"	1"	1 1/4"	1 1/2"	2"
S	5	5	6	7	7	7.5
F	25	25	25	45	45	45
K	M6	M6	M6	M8	M8	M8
L	124	144	154	174	194	224
t_{SS}¹	16	19	22	26	31	38
M_{PVC}	17	17	21	33	33	40.5
N_{PVC}	19	19	20	31	31	34.5
M_{PP / PVDF}	16.5	16.5	20	25.5	32	38.5
N_{PP / PVDF}	18	18	21	24	29	34.5
Drive	K62	K62	K82-62*	K82	K122	K123
H	129.5	129.5	151	151	240	240
I	80	80	100	100	160	160
J	52	52	60.5	60.5	87	87
X	32	32	32	32	32	32
Y	12	12	12	12	12	12
Z	24	24	24	24	30	30

*For version PO-NC with PTFE-Membrane
¹ SS = Solvent spigot

Dimensions in mm

Diaphragm valve T4

with pneumatic actuating drive

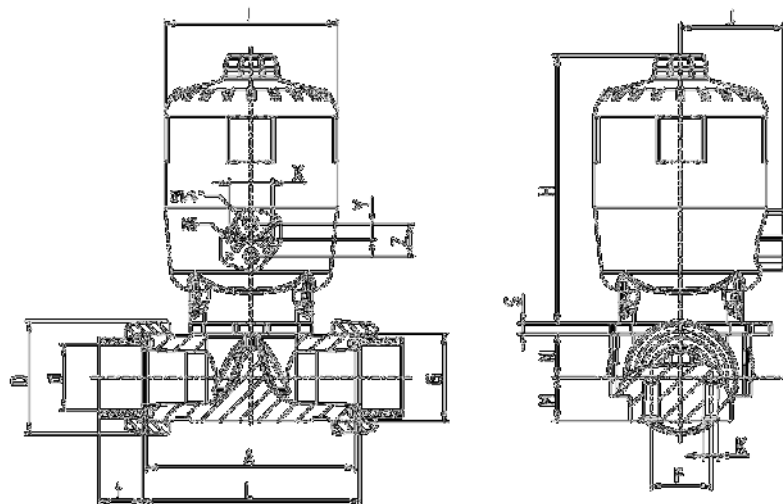

PVC-U / PP / PVDF
Connector type
 PVC solvent socket
 PE / PP / PVDF fusion socket

	DN	15	20	25	32	40	50
	d	20	25	32	40	50	63
	inch	1/2"	3/4"	1"	1 1/4"	1 1/2"	2"
	G	1"	1 1/4"	1 1/2"	2"	2 1/4"	2 3/4"
	F	5	5	6	7	7	7.5
	F	25	25	25	45	45	45
	K	M6	M6	M6	M8	M8	M8
PVC	t _{SS} ¹	16	19	22	26	31	38
	t _{FS} ² PE	16	17.5	19.5	22	25	29
	A	90	108	116	136	154	184
	D	44	53	60	74	83	103
	M	17	17	21	33	33	40.5
	L	97	114	122	142	160	190
	L _{FS} ² PE	95	116	126	148	173	209
PP / PVDF	t _{FS} ²	16	18	20	22*	24.5	29
	A	90	108	116	136	154	184
	D	47	57	64	78	89	109
	M	17	17	20	25.5	32	39
	N	18	18	21	24	29	34.5
	L	96	114	122	142*	161	190
	Drive	K62	K62	K82-K62*	K82	K122	K123
	H	129.5	129.5	129.5	151	151	240
	I	80	80	100	100	160	160
	J	52	52	60.5	60.5	87	87
	X	32	32	32	32	32	32
	Y	12	12	12	12	12	12
	Z	24	24	24	24	30	30

*For version PO-NC with PTFE-Membrane
¹ SS = Solvent socket ² FS = Fusion socket

Dimensions in mm



+612 9615 9774

contact@mandalaypcf.com.au

www.mandalaypcf.com.au

Diaphragm valve T4 with pneumatic actuating drive

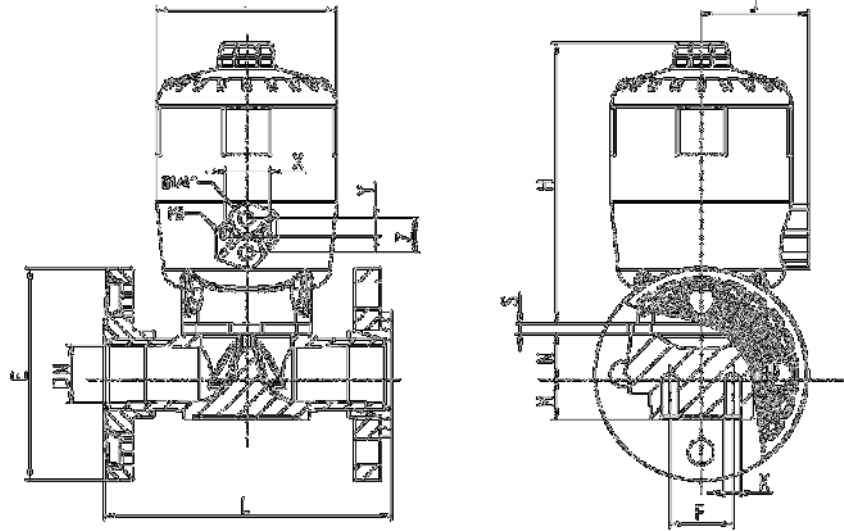

PVC-U / PP / PVDF

Connector type

PVC/PP fix flange

PVDF with PP backing flange with steel inlay

	DN	15	20	25	32	40	50
	d	20	25	32	40	50	63
	inch	1/2"	3/4"	1"	1 1/4"	1 1/2"	2"
	S	5	5	6	7	7	7
	F	25	25	25	45	45	45
	K	M6	M6	M6	M8	M8	M8
PVC	E _{FF} ²	97	105	125	140	150	165
	M	17	17	21	33	33	40.5
	N	19	19	20	31	31	34.5
	L _{FF} ²	130	150	160	180	200	230
PP / PVDF	E _{PVDF BF} ¹	95	-	-	-	-	-
	E _{PP FF} ²	95	-	-	-	-	-
	M	17	17	20	25.5	32	39
	N	18	18	21	24	29	34.5
	L _{PVDF BF} ¹	130	-	-	-	-	-
	L _{PP FF} ²	130	-	-	-	-	-
	Drive	K62	K62	K82-62*	K82	K122	K123
	H	129.5	129.5	151	151	240	240
	I	80	80	100	100	160	160
	J	52	52	60.5	60.5	87	87
	X	32	32	32	32	32	32
	Y	12	12	12	12	12	12
	Z	24	24	24	24	30	30

*For version PO-NC with PTFE-Membrane

¹ BF = Backing flange

² FF = Fix flange

Dimensions in mm

Diaphragm valve T4

with pneumatic actuating drive

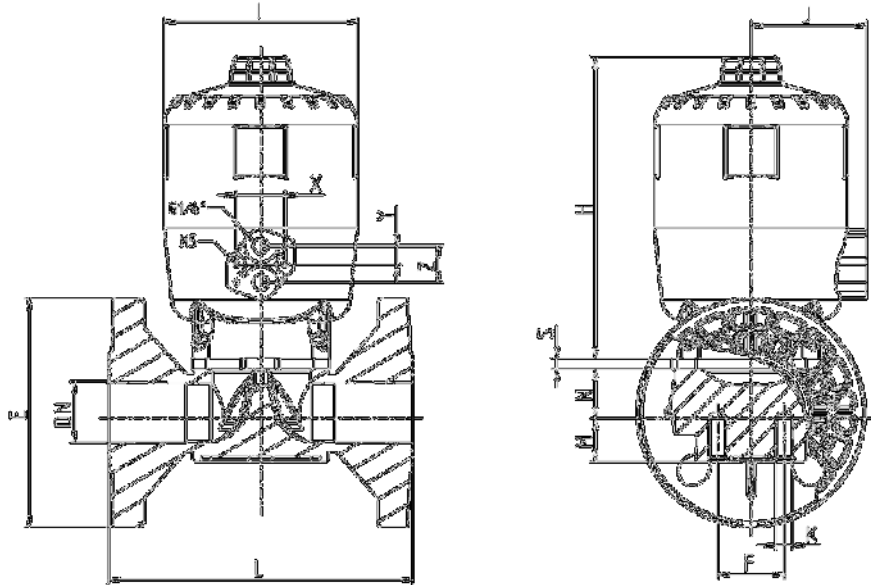

PP / PVDF
Connector type
 PP / PVDF fix flange

DN	20	25	32	40	50
d	25	32	40	50	63
inch	3/4"	1"	1 1/4"	1 1/2"	2"
S	5	6	7	7	7.5
F	25	25	45	45	45
K	M6	M6	M8	M8	M8
M	17	20	25.5	32	39
N	18	21	24	29	34.5
E	105	125	140	150	165
L	150	160	180	200	230
Drive	K62	K82-62*	K82	K122	K123
H	129.5	151	151	240	240
I	80	100	100	160	160
J	52	60.5	60.5	87	87
X	32	32	32	32	32
Y	12	12	12	12	12
Z	24	24	24	30	30

*For version PO-NC with PTFE-Membrane

Dimensions in mm

Diaphragm valve T4

with pneumatic actuating drive



Exploded drawing:

- 01. Pneumatic actuating drive
- 02. Diaphragm
- 03. Flange adaptor
- 04. Flange
- 05. Lower part
- 06. Washer
- 07. Hexagon bolt
- 08. Cap
- 09. O-ring
- 10. Solvent socket
- 11. Union nut

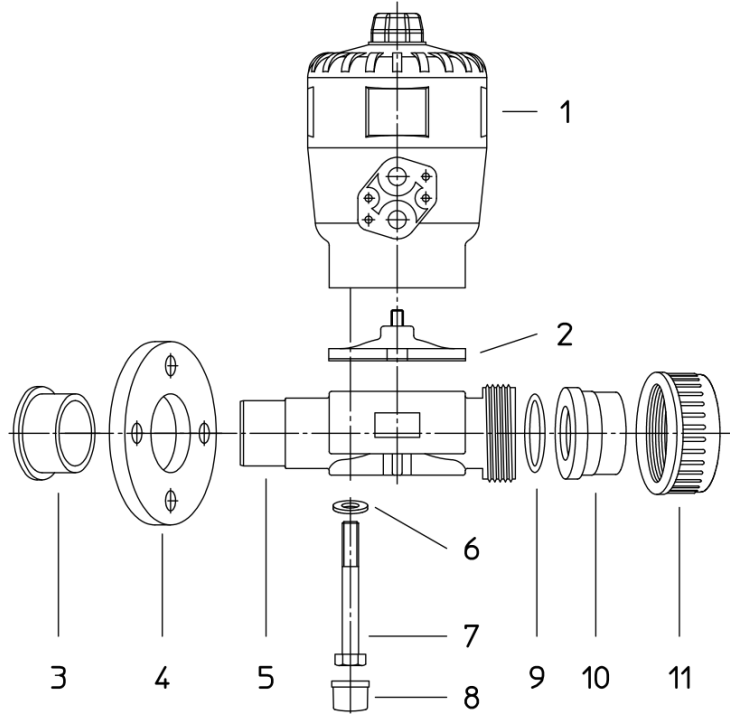

Diagrams:

Pressure loss diagram

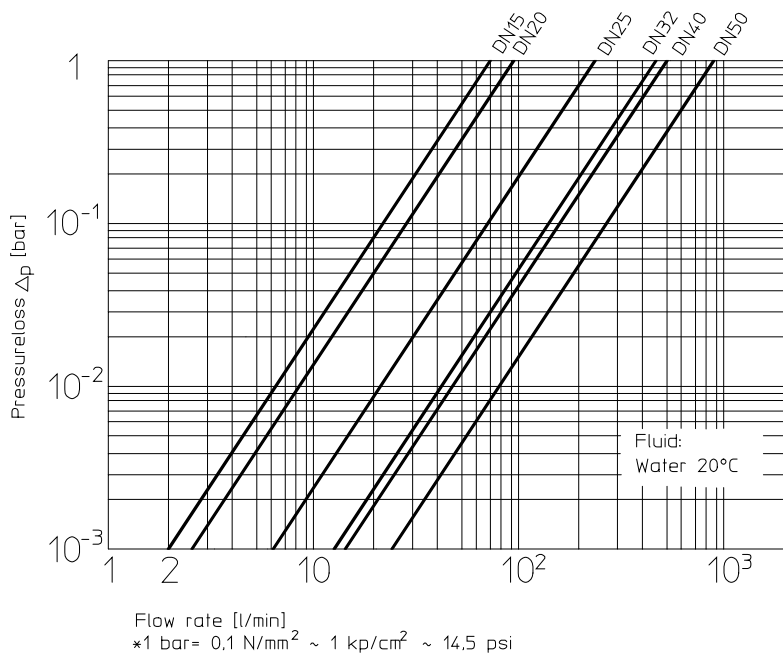

Cv value table

Pressure loss	DN15	DN20	DN25	DN32	DN40	DN50	DN65	DN80	DN100	DN125
1 bar	70 l/min	95 l/min	250 l/min	450 l/min	500 l/min	880 l/min	1.100 l/min	1.700 l/min	2.700 l/min	4.000 l/min

Diaphragm valve T4

with pneumatic actuating drive



Pressure – Temperature diagram – PVC-U

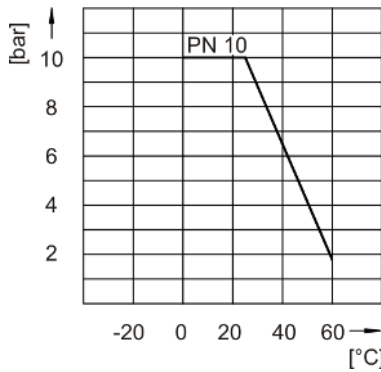

Pressure – Temperature diagram - PP

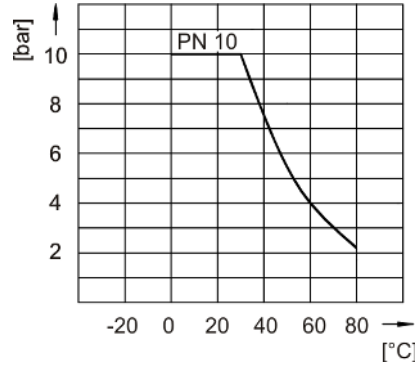

Pressure – Temperature diagram - PVDF

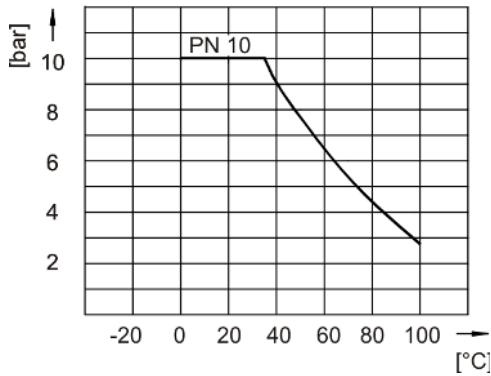

Tightening torque of screws

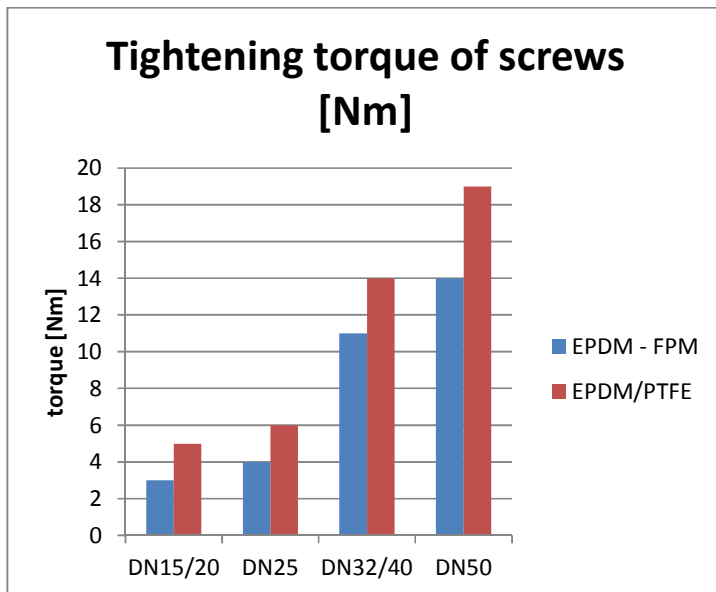

Tightening torque of screws [Nm]		
Dimension	EPDM - FPM	EPDM/PTFE
DN15/20	3	5
DN25	4	6
DN32/40	11	14
DN50	14	19

Diaphragm valve T4 with pneumatic actuating drive

Emptying of diaphragm valves

In order to achieve the optimum emptying of the diaphragm valve in horizontal mounted piping systems, we recommend the installation of the diaphragm valve according to the respective angle of rotation and an installation down-grade about 2°.

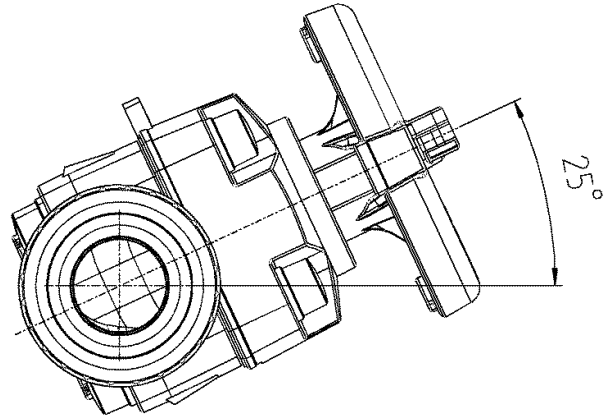

Control pressure technical data:

Drive	Control pressure
K62	5.5 – 8.5 bar
K82-62	5.5 – 8.5 bar
K82	5.5 – 8.5 bar
K122	5.5 – 8.5 bar
K123	5.5 – 8.5 bar

Accessories:

Solenoid Valve NAMUR

General:

- Solenoid valve NAMUR with combined 5/2- and 3/2- ways function + standard coil
- Easy switch from 5/2- to 3/2-ways by turning around the sealing-plate
- Manual override as standard

Material:

- Body: aluminium anodized
- Piston: aluminium
- Seals: NBR
- Screws and spring: stainless steel

Voltage:

- 24 V DC (3W)
- 230 V AC (5VA)

ATTENTION: For diaphragm valves with pneumatic actuating drive K122 / K123 (DN32 - DN50) an additional adapter (item 50826) is required.

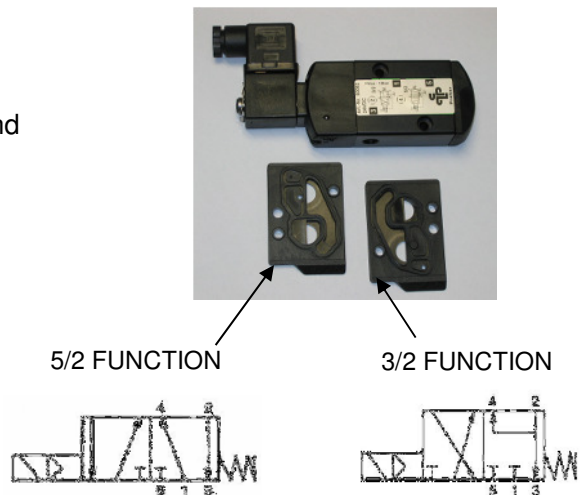

Diaphragm valve T4
with pneumatic actuating drive

Electrical position indicator

Specifications

Body	: Polyamide
Cover:	: Polycarbonate
Connector	: PG11 union
Ambient temperature	: -10°C to +80°C
Voltage ranges	: 12-24 V AC/DC
	: 110 – 250 V AC/DC
Degree of protection	: IP65



Electropneumatic positioner

Specifications

Body	: Aluminum anodized
Seals	: NBR / FKM
Medium	: Air or neutral gases filtered, oiled or unoled
Connector	: G 1/8"
Pressure range	: Max. 10 bar input pressure
Temperature	
▪ Medium	: 0°C to 60°C
▪ Environment	: 0°C to 50 °C
Setpoint	: 0 – 10 V
	: 0 – 20 mA
	: 4 – 20 mA
Degree of protection	: IP65
Voltage	: 24V
Following voltage failure	: Optionally, the position is held or the drive is vented

