

DHV 718 PRESSURE RELIEF VALVES

DATASHEET

PVC-U

PP

PVDF

1.4571

Nominal size DN 8 - 50**Nominal size in inches 1/4 - 2****Nominal pressure PN in bar 10****Pressure setting range in bar 0,5 - 10****Characteristics**

- diaphragm controlled pressure relief valve
- simple design, reliable function
- particularly suitable for oscillating pumps
- constant, frictionless and low vibration control behaviour
- high reproducibility of the set pressure
- simple pressure setting possible at any time, also during operation

<https://www.stuebbe.com/en/products-and-systems/instrumentation/>



Pictogram

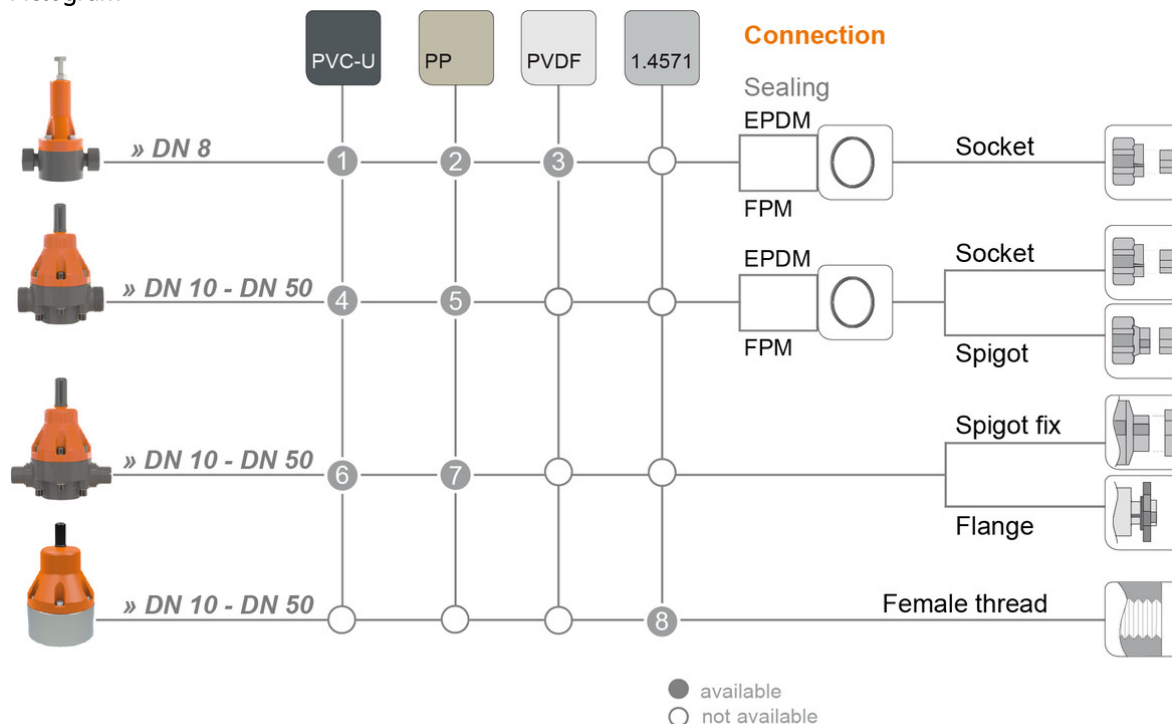

Diaphragm: PTFE (EPDM)

Options: pressure settings in 0.5 bar steps

On demand: sealing
cleaning (free of surface disturbing substances)

Pressure setting range:
0.5–10 bar



Basic Nominal Sizes:

DN 8	DN 10	DN 15	DN 20	DN 25	DN 32	DN 40	DN 50	DN 65	DN 80	DN 100	DN 125	DN 150	DN 200	DN 250	DN 300	DN 350	DN 400
------	-------	-------	-------	-------	-------	-------	-------	-------	-------	--------	--------	--------	--------	--------	--------	--------	--------

Connection Material (process connection)

① **PVC-U** socket **DIN**
DN 8.

② **PP** socket **DIN**
DN 8.

③ **PVDF** socket **DIN**
DN 8.

④ **PVC-U** socket **DIN, ANSI, BS, JIS**
female thread Rp, NPT
1.4571 male thread R
female thread Rp
DN 10–50.
PE100 spigot **DIN** (95 mm)
DN 15–50.

⑤ **PP** socket **DIN**
female thread Rp
DN 10–50.
PP spigot (IR)
DN 15–50.

⑥ **PVC-U** spigot fix DN 10–50.
PP/St. flange **DIN, ANSI** DN 15–50.
GFK flange **DIN** DN 15–50.

⑦ **PP** spigot fix DN* 10–50.
PP/St. flange **DIN, ANSI** DN 15–50.
GFK flange **DIN** DN 15–50.

⑧ **1.4571** female thread Rp
female thread NPT
DN 10–50.
* only for socket welding.

DHV 718 Pressure relief valves

Use	<ul style="list-style-type: none"> - Chemical plant manufacture - Water treatment - Industrial plants - electroplating plants
Application	<ul style="list-style-type: none"> - The pressure relief valve which is directly controlled by the medium, is used in technical processing plants for keeping preset working pressures constant on the primary side. - The pressure relief valve can also be used as an overflow valve to prevent pressure peaks. In this case, the pressure relief valve is fitted in a bypass line. - Return flow is excluded by the DHV 718
Device connection	- see pictogram
Flow medium	- Neutral and aggressive fluid media with some solid particles, provided that the valve components coming into contact with the media are resistant at the operating temperature in accordance with the STÜBBE resistance guide.
STÜBBE resistance guide	- www.stuebbe.com/pdf_resistance/300051.pdf
Valve function	- When the valve is closed in the position of rest, the diaphragm under the valve seat is only impinged by the low secondary pressure. Any rise in working or primary pressure lifts the diaphragm against the spring force. The valve opens and the pressure decreases.
Valve setting	<ul style="list-style-type: none"> - can be adjusted easily across the entire pressure range - can be secured against unauthorized opening by sealing
Housing material (with medium contact)	<ul style="list-style-type: none"> - DN 8: PVC-U, PP, PVDF - DN 10 - 50: PVC-U, PP, 1.4571
Material sealing element (in contact with medium)	<ul style="list-style-type: none"> - EPDM - FPM
Material membrane (with medium contact)	- PTFE (EPDM)
Housing upper part (without medium contact)	- PP (glass fiber reinforced)
Material screws (without medium contact)	- 1.4301
Nominal pressure PN in bar	- 10
Pressure setting range in bar	- 0,5 - 10
Opening pressure in bar	<ul style="list-style-type: none"> - DN 8: 0.5 bar - DN 10–50: 0.3 bar
Flow direction	- see graphics „sectional drawing“

DHV 718 Pressure relief valves

Colours	<ul style="list-style-type: none">- Casing: PVC-U, grey RAL 7011- Casing: PP, grey RAL 7032- Casing: PVDF, opaque, yellowish-white- Casing: stainless steel, bright- Bonnet: PP glass fiber reinforced, orange RAL 2004- protection cap: black
Mounting position	<ul style="list-style-type: none">- any
Actuation	<ul style="list-style-type: none">- medium-controlled
Fastening	<ul style="list-style-type: none">- via threaded inserts (metal inserts) in the valve body
Application limits	<ul style="list-style-type: none">- When the valve is in the position of rest, the counterpressure (secondary pressure) may be approx. 4 times than the set pressure pE, the valve remains closed- Pressure relief valves are not safety valves in the sense of the pressure vessel directive- Please note that, while PTFE has almost universal chemical resistance, the service life of PTFE-coated diaphragms may be reduced by medium types with a permeation tendency (e.g.: hydrofluoric acid, nitric acid, hydrochloric acid).
CE Conformity	<ul style="list-style-type: none">- Pressure equipment directive 2014/68/EU
Additional options on demand	<ul style="list-style-type: none">- silicon free- pressure presetting- sealed- NSF certification
Weblink Product	<ul style="list-style-type: none">- https://www.stuebbe.com/en/products-and-systems/instrumentation/

DHV 718 Pressure relief valves

Pressure and temperature diagram PVC-U

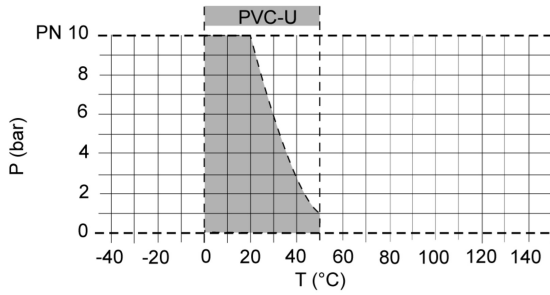

Pressure and temperature diagram PP

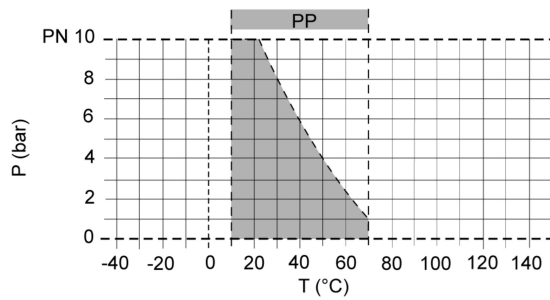

Pressure and temperature diagram PVDF

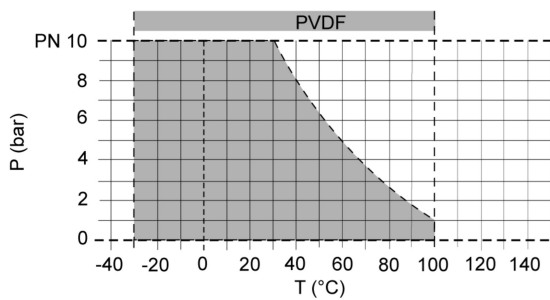

DHV 718 Pressure relief valves

Pressure and temperature diagram 1.4571

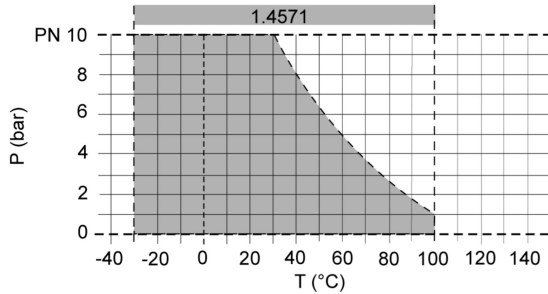

P = Operating pressure

T = Temperature

The pressure/temperature limits of the materials are valid for the stated nominal pressures and a service life of 25 years. These values are guide values for flow medium types which do not negatively impact the physical and chemical characteristics of the valve material. It may be necessary to take diminution factors into consideration.

DHV 718 Pressure relief valves

Pressure loss curve (standard values for H₂O, 20°C)

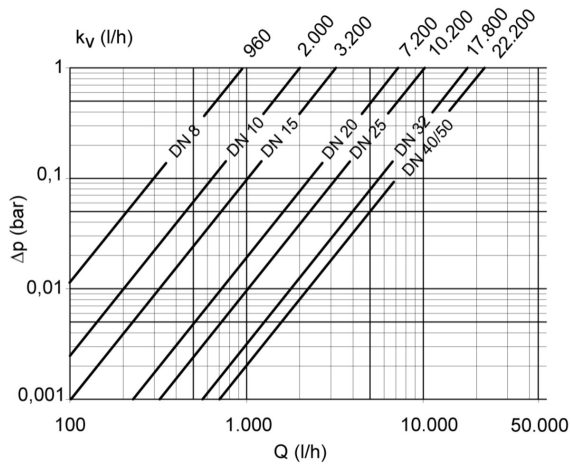

Δp = Pressure loss

Q = Flow

pressure loss and kv value:

The diagram shows the pressure loss Δp in relation to the flow Q .

DHV 718 Pressure relief valves

Operating behavior

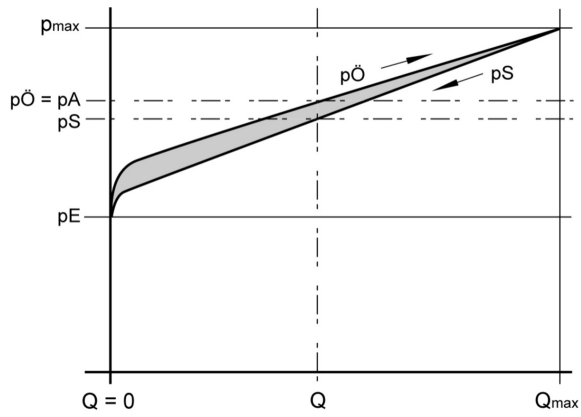

p_{max} = maximum pressure

p_A = Working pressure

p_E = Set pressure

p_A-p_E = flow-dependent pressure increase

p_O = Opening pressure

p_S = Closing pressure

p_O-p_S = Hysteresis

Q = Flow

Q_{max} = maximum flow

DHV 718 Pressure relief valves

Characteristic curve, design example

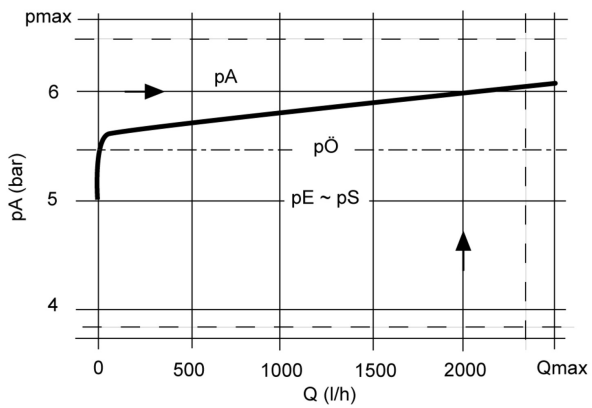

p_{max} = Maximum pressure

p_A = Working pressure

p_E = Set pressure

$p_{\ddot{O}}$ = Opening pressure

p_S = Closing pressure

Q = Flow

Q_{max} = Maximum flow

The valve is set tight at 5 bar.

A flow of approx. 2000 l/h is reached
at a pressure increase of 1 bar.

According to the curve, this results in the following values:

Set pressure p_E : 5 bar

Working pressure p_A : 6 bar

Opening pressure $p_{\ddot{O}}$: 5.5 bar

Closing pressure p_S : 5 bar

DHV 718 Pressure relief valves

Characteristic curve DN 8

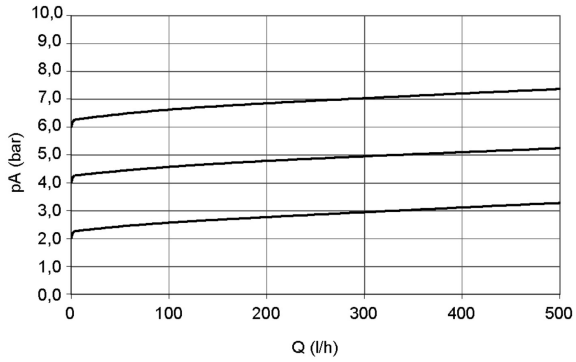

Characteristic curve DN 10

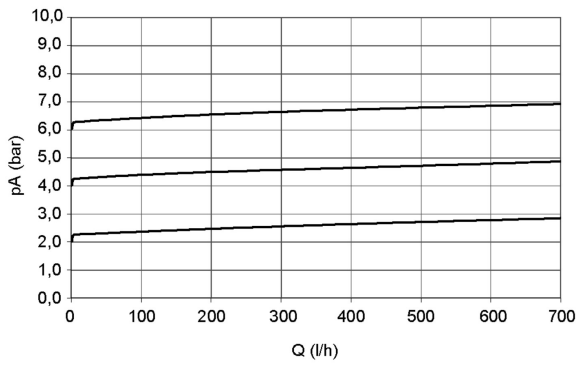

Characteristic curve DN 15

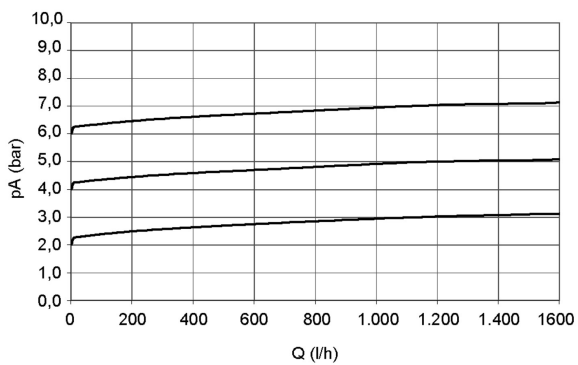

DHV 718 Pressure relief valves

Characteristic curve DN 20

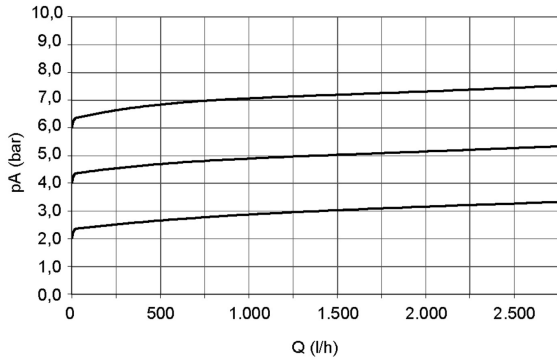

Characteristic curve DN 25

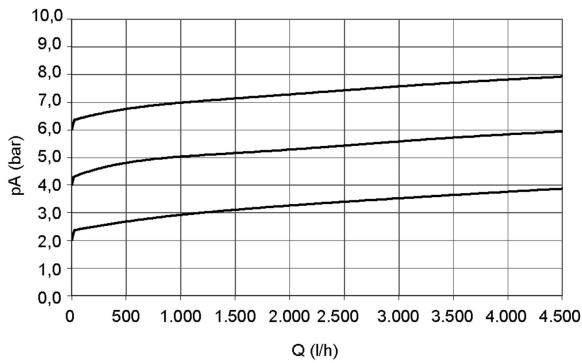

Characteristic curve DN 32

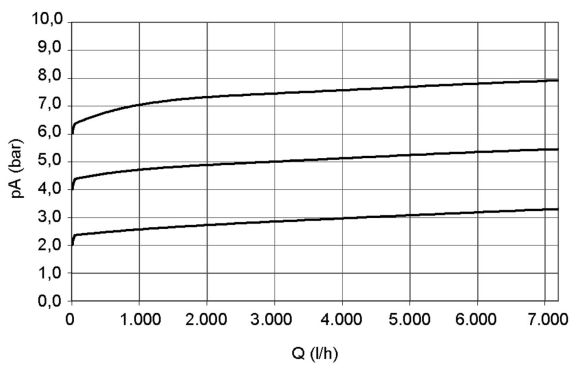

DHV 718 Pressure relief valves

Characteristic curve DN 40

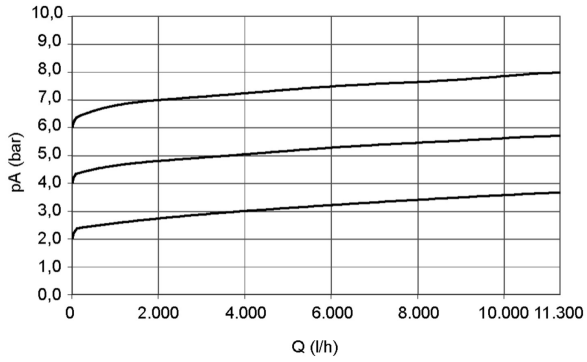

Characteristic curve DN 50

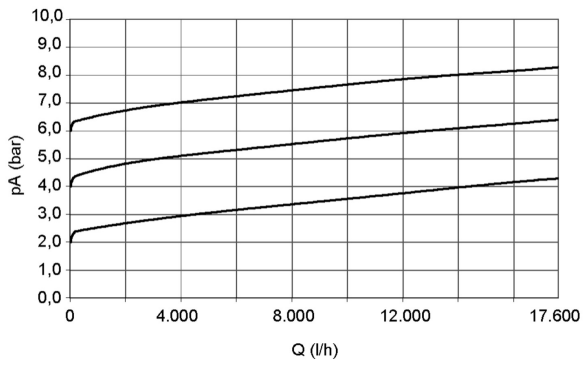

pA = Working pressure

Q = Flow

DHV 718 Pressure relief valves

Connection spigot end /socket

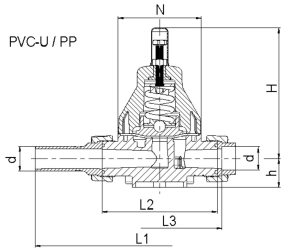

Connection spigot fixed /flange

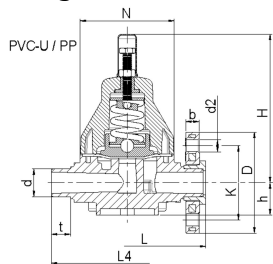

Dimensioned drawing

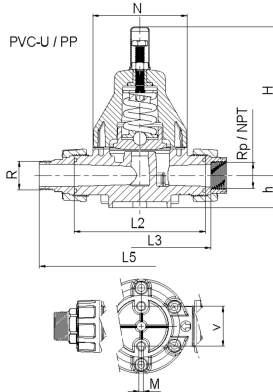

		d	16	20	25	32	40	50	63
DN			10	15	20	25	32	40	50
DN*			3/8	1/2	3/4	1	1 1/4	1 1/2	2
	Valve body	Insert/flange							
b		GFK flange DIN	-	12.2	14	15	17	17	18.5
		PP steel flange DIN	-	13	14.5	15.5	17.5	17.5	19
		PP steel flange ANSI	-	12	12	16	16	18	18
d		GFK flange DIN	-	14	14	14	18	18	18
		PP steel flange DIN	-	14	14	14	18	18	18
		PP steel flange ANSI	-	16	16	16	16	16	20
D		GFK flange DIN	-	96.5	106	115	142	152	168
		PP steel flange DIN	-	96	106	116	141	151	166
		PP steel flange ANSI	-	95	105	113	130	133	160
G*			3/4	1	1 1/4	1 1/2	2	2 1/4	2 3/4
h	PVC-U, PP		25	25	37	37	57	57	57
H	PVC-U, PP		151	151	170	170	219	219	219
K		GFK flange DIN	-	65	75	85	100	110	125
		PP steel flange DIN	-	65	75	85	100	110	125
		PP steel flange ANSI	-	60	70	80	89	98	121
L	PVC-U		-	150	180	180	230	231.4	250
	PP		-	150	180	180	230	230	250.4
L1	PVC-U	PE100 spigot end DIN	-	-	340	340	405	433	453
	PP	PP spigot end	-	228	264	270	331	338	343
L2	PP, PVC-U		120	120	150	150	205	205	205
L3	PVC-U	Socket PVC-U DIN	126	126	156	156	211	211	211
		PVC-U ANSI, BS							
		Socket PVC-U JIS	132	128	160	159	211	211	213
		PVC-U female thread Rp	126	127.6	158	162.6	221	226	235.6
		PVC-U female thread NPT	126	124	162	162	211	217	217
		Female thread Rp 1.4571	130	130	161	164	221	223	223
	PP	PP socket DIN	128	126	156	156	211	211	211
		PP female thread Rp	126	126	157	156.6	212	213	214
L4	PVC-U, PP		144	144	174	174	224	224	244
L5	PVC-U	Male thread R 1.4571	182	188	222	230	297	301	315
M			M6	M6	M6	M6	M8	M8	M8
N			81.5	81.5	108	108	148	148	148
NPT*			3/8	1/2	3/4	1	1 1/4	1 1/2	2
Rp*			3/8	1/2	3/4	1	1 1/4	1 1/2	2
t			14	16	19	22	26	30	38
V			40	40	46	46	65	65	65

all dimensions in mm / * in inch

DHV 718 Pressure relief valves

Dimensioned drawing

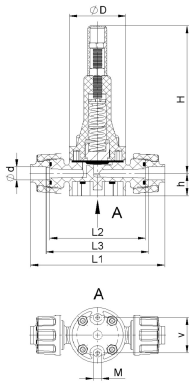

d	12
DN	8
DN*	1/4
H	134
h	20
L1	119
L2	85
L3	91
M	M 5
N	50
v	32

all dimensions in mm / * in inch

Connection female thread A4 (1.4571)

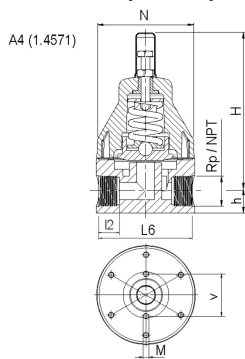

d	16	20	25	32	40	50	63
DN	10	15	20	25	32	40	50
DN*	3/8	1/2	3/4	1	1 1/4	1 1/2	2
h	16	16	24	24	27,5	30	35
H	151	151	175	175	220	222,5	230,5
L2	16	18	20	22	25	25	25
L6	79	79	103	103	142	140	136
M	M6	M6	M6	M6	M8	M8	M8
N	81,5	81,5	108	108	148	148	148
NPT*	3/8	1/2	3/4	1	1 1/4	1 1/2	2
Rp*	3/8	1/2	3/4	1	1 1/4	1 1/2	2
V	40	40	46	46	65	65	65

all dimensions in mm / * in inch

DHV 718 Pressure relief valves

Sectional drawing DN 8

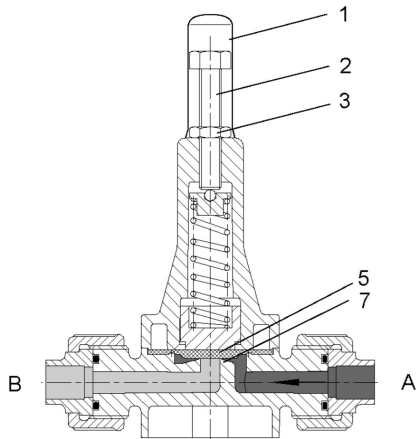

Sectional drawing DN 10-15

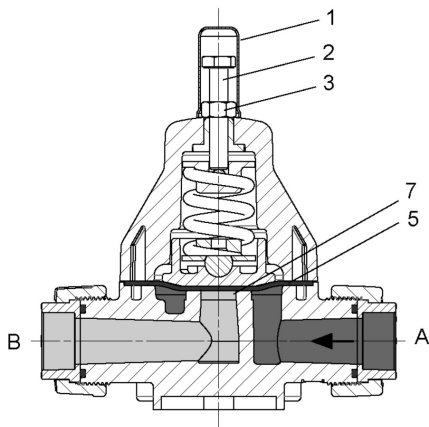

A = Primary side

B = Secondary side

1 = Protection cap

2 = Adjustment screw

3 = Counter nut

5 = Diaphragm

7 = Valve seat

DHV 718 Pressure relief valves

Components DN 8

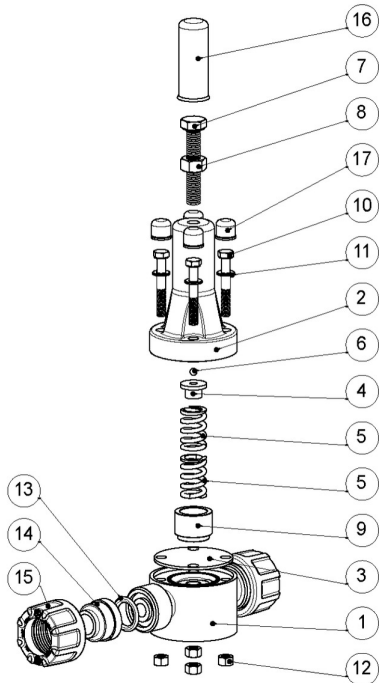

	Quantity	Description
1	1	Housing, complete
2	1	Bonnet
3	1	Diaphragm
4	1	Pressure plate
5	2	Pressure spring
6	1	Steel ball
7	1	Hexagon screw
8	1	Hexagon nut
9	1	Spring plate
10	4	Cylinder screw
11	4	Washer
12	4	Hexagon nut
13	2	O-ring
14	2	Union end
15	2	Union nut
16	1	Protection cap
17	4	Protection cap

DHV 718 Pressure relief valves

Components: DN 10-50, Housing: stainless steel A4
(1.4571)

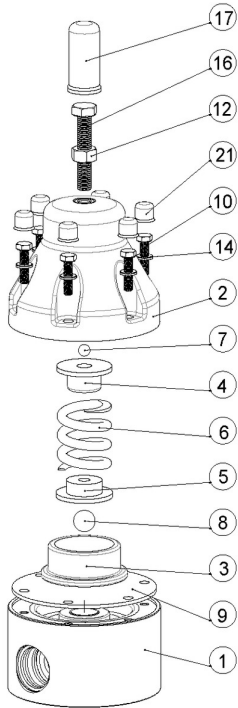

Quantity	Description
1	Housing, complete
2	Bonnet
3	diaphragm disc
4	Pressure plate
5	Spring plate
6	Pressure spring
7	Steel ball
8	Steel ball
9	Diaphragm
10	Hexagon screw
12	Hexagon nut
14	Washer
16	Hexagon screw
17	Protection cap
21	Protection cap

DHV 718 Pressure relief valves

Components DN 10-50, Housing: PVC-U, PP

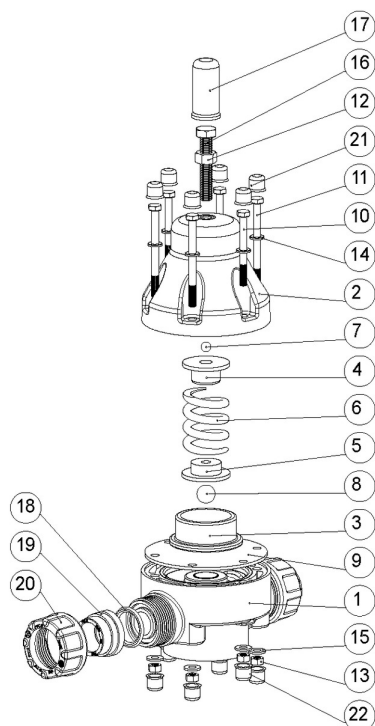

	Quantity	Description
1	1	Housing, complete
2	1	Bonnet
3	1	diaphragm disc
4	1	Pressure plate
5	1	Spring plate
6	1	Pressure spring
7	1	Steel ball
8	1	Steel ball
9	1	Diaphragm
10	4	Hexagon screw
11	2	Hexagon screw
12	1	Hexagon nut
13	6	Hexagon nut
14	6	Washer
15	6	Washer
16	1	Hexagon screw
17	1	Protection cap
18	2	O-ring
19	2	Union end
20	2	Union nut
21	6	Protection cap
22	6	Protection cap

DHV 718 Pressure relief valves

Example 1: Generation of a constant operating pressure

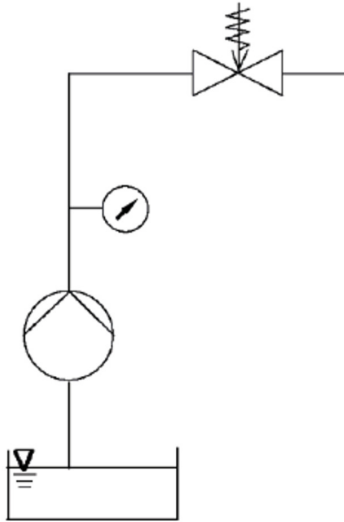

Example 2: Use with high primary pressure

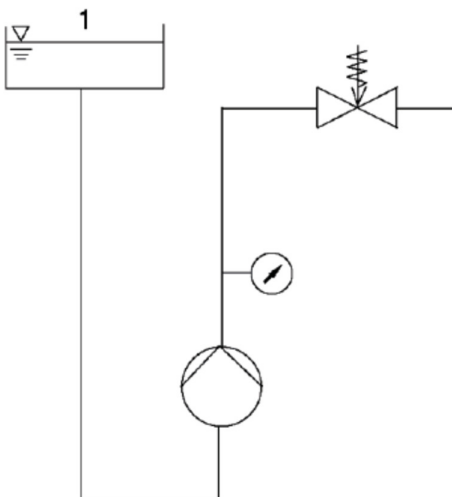

DHV 718 Pressure relief valves

Example 3: Reduction of pressure impacts due to an overflow valve to protect the plant

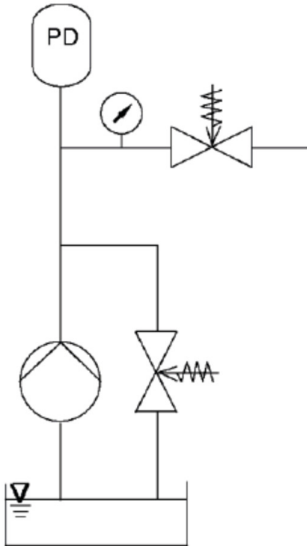

PD= pulsation damper