

Sampling ball valve S4

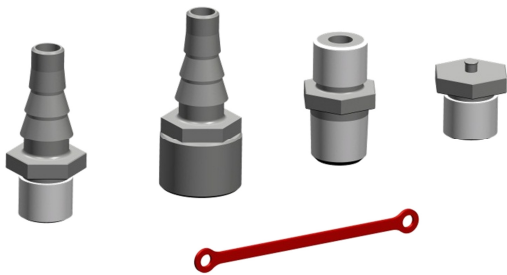

PVC-U sampling ball valve with accessories

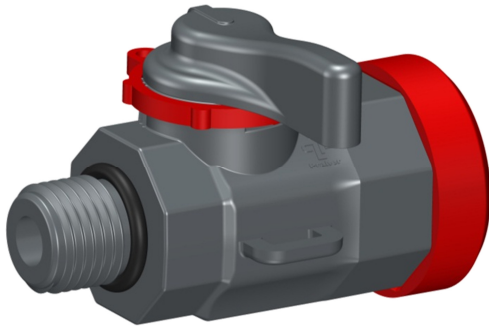
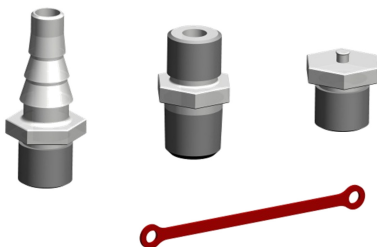
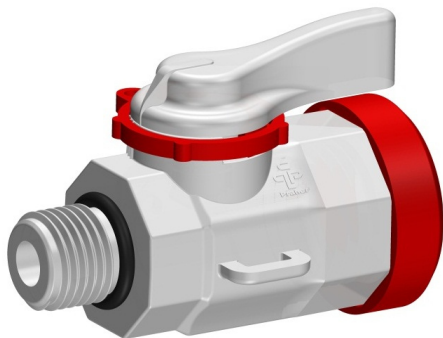

PVDF Sampling ball valve with accessories

General:

- Material: PVC-U / PVDF
- Sealing material: EPDM / FPM
- Ball seating joint: PTFE
- Dimensions: DN6

Connector types:

PVC-U

- Body: BSP / NPT
- Hose nozzle Male thread: BSP / NPT
- Hose nozzle Female thread: BSP / NPT
- Double nipple: BSP - NPT, NPT - NPT
- Plug: BSP

PVDF

- Body: BSP / NPT
- Hose nozzle Male thread: BSP
- Double nipple: BSP / NPT
- Plug: BSP

Operating pressure:

- DN6 1/4" 3/8" PN 10

Technical features:

- Lock and metering ring for protection of sampling ball valve from any unwarranted opening
- Lock and metering ring for adjustment of ball opening angles
- Sampling ball valve can be 100% opened at any time by removing the lock and metering ring
- Compact design
- Low weight
- Corrosion resistant
- PVDF Sampling ball valve is Oil & Silicone-free

This document does not constitute a guarantee, it is for initial information purposes only. The product range is continually upgraded, the design and types therefore only reflect the state of the art at the time of printing.
Subject to technical modifications!

Sampling ball valve S4

Dimensions:

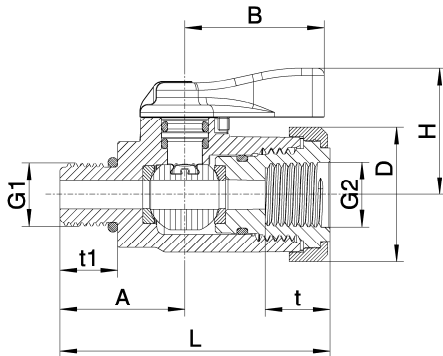

Laboratory ball valve

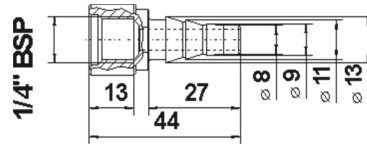

Hose nozzle female thread

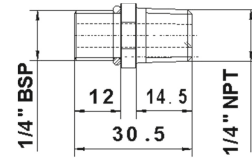

Double nipple

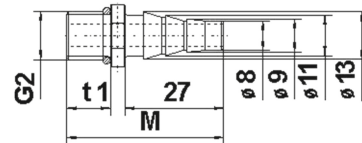

Hose nozzle male thread

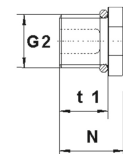

Plug

	G1	G2	A	B	D	H	L	M	N	t	t1	PN
PVC-U	1/4" BSP	1/4" BSP	26	29	28	26,5	56	43	16	13,5	12	10
	3/8" BSP	1/4" BSP	26	29	28	26,5	56	43	16	13,5	12	10
	1/4" NPT	1/4" NPT	28,5	29	28	26,5	58,5	45,5	18,5	13,5	14,5	10
PVDF	1/4" BSP	1/4" BSP	26	28,2	28	26	56	43	16	13,2	12	10
	1/4" NPT	1/4" NPT	28,5	28,2	28	26	58,5	45,5	18,5	13,2	14,5	10

Exploded drawing:

01. Handle
02. O-ring
03. Lock and metering ring
04. O-ring
05. Body
06. Ball seating joint
07. Ball
08. O-ring
09. Thrust collar
10. Circlip
11. Hose nozzle male thread
12. Double nipple
13. Plug
14. Clip tie
15. Hose nozzle female thread

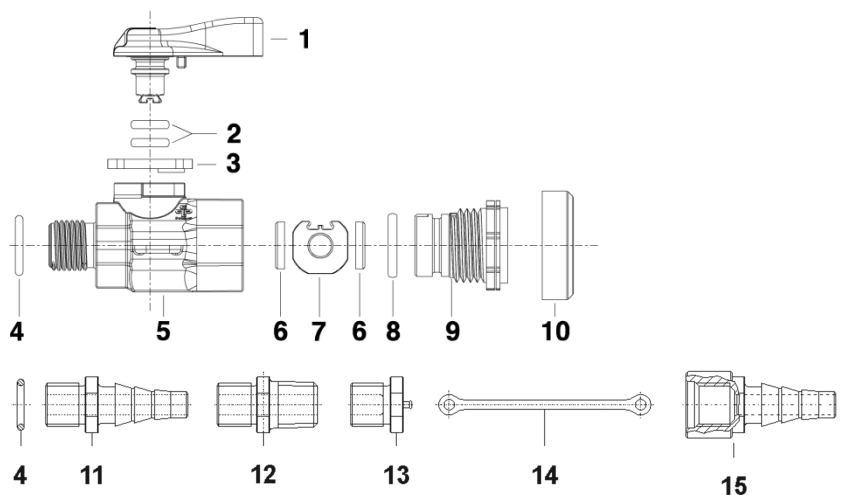

Sampling ball valve S4

Additional features:



When not in use, lock and metering ring can be hung on sampling ball valve body

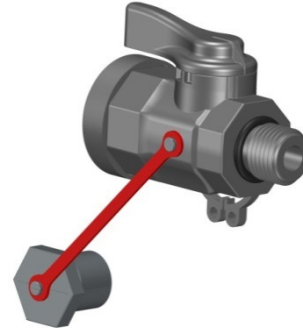

When not in use, plug can be fixed with the clip tie on the sampling ball valve body.

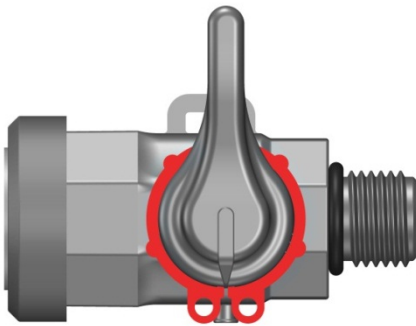

In closed position, the lock and metering ring protects the valve against unwarranted opening.

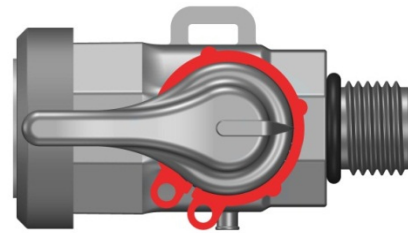

In open position, the locking ring protects the valve against unwarranted closing.



The sampling ball valve can be installed on the pipeline with a wrench SW22 or SW24.



The three metering marks serves as guidance for flow regulation.

Sampling ball valve S4

Diagrams:

Flow characteristics

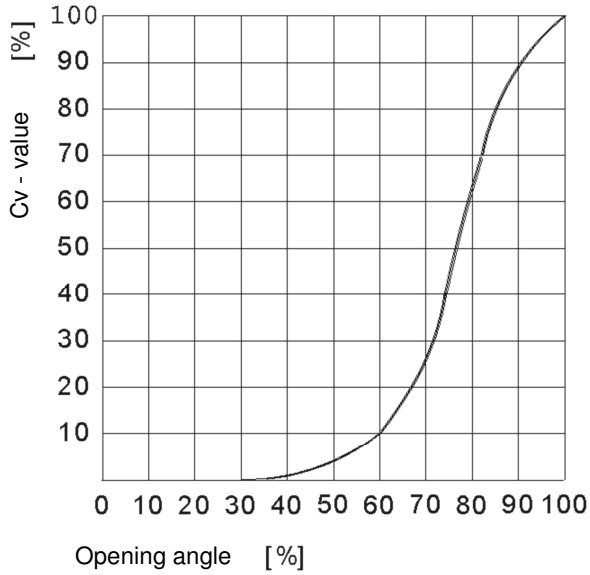

Pressure-temperature-diagram

