

## Butterfly Valve K4 with hand lever



### **General:**

- Sealing material: EPDM  
FPM
- Body material: PP-GF
- Disc material: PVC-U, PP or PVDF
- Dimensions: DN65 – DN200  
d75 – d225  
2 1/2" – 8"
- Flange connections: DIN 2501 PN 10  
ANSI B 16,5 Class 150  
JIS 10 K [for DN65-DN150 only\*]  
BS Table D&E
- Additional dimension: DN65/d63 PVC-U  
DIN 2501 PN 10

\* for mounting between JIS-Flanges DN200 please contact us

### **Operating pressure:**

PVC-U, PP, PVDF      PN 10

### **Technical characteristics:**

- only sleeve gasket and disc in touch with medium
- double sealed shaft
- integrated bracket for fix point mounting
- simple and quick assembling of the actuator without any extra parts
- 10 different disc locking positions
- reliable „Locking-handle-system“
- Hand lever with marking plate (different colours available)
- Metal adapter between handle and shaft avoids abrasion of the handle

This print contains no warranty promise, but it should give you some first information. The product range is extended continuously, therefore the versions and types correspond to the actual status of printing.  
Subject to technical modifications!

# Butterfly Valve K4 with hand lever



**Dimensions:**

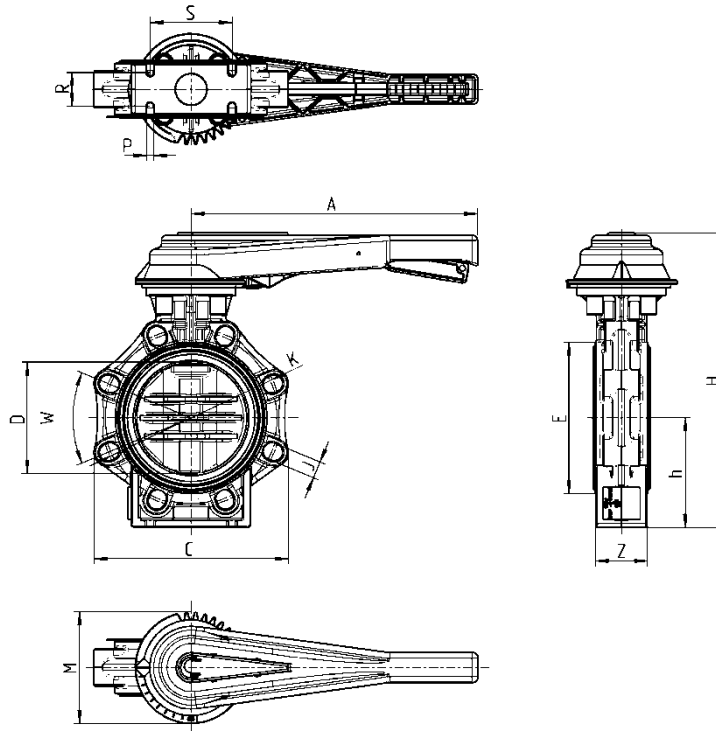

DN	65	80	100	125	150	200
d	75	90	110	140	160	225
G	2 1/2"	3"	4"	5"	6"	8"
A	230	230	300	300	386	386
D	65	80	100	125	150	200
C	133	176	206	234,5	261	314
W	90°	45°	45°	45°	45°	45°
J	19	19	19	23	23	23
K	127–145	146–160	175–190,5	209,5–216	234,5–241,3	290–298,5
H	285	292	322	358	396	458
h	100	100	115	130	147,5	175
E	98	116	146	170	196	251
M	114	114	114	114	150	150
Z	46	49	56	64	70	71
S	55	70	85	100	110	145
R	25	30	35	45	45	40
P	7	9	9	9	9	9
PN	10	10	10	10	10	10

Dimensions in mm

© Praher Plastics Austria GmbH DB/DE/18/08/202/D Subject to change without prior notice!



+612 9615 9774

contact@mandalaypcf.com.au

www.mandalaypcf.com.au



# Butterfly Valve K4 with hand lever

**Exploded drawing:**

- 01. Body
- 02. Sleeve
- 03. Disc
- 04. Shaft
- 05. Seal shaft below
- 06. Seal shaft above
- 07. Seal pilot bushing
- 08. Pilot bushing
- 09. Retaining ring
- 10. Holding disc
- 11. Screw
- 12. Cap
- 13. Cover plate
- 14. Screws
- 15. Tooth wheel
- 16. Nuts
- 17. Caps
- 18. Handle
- 19. Lever
- 20. Pin
- 21. Spring
- 22. Washer
- 23. Screw
- 24. Marking plate

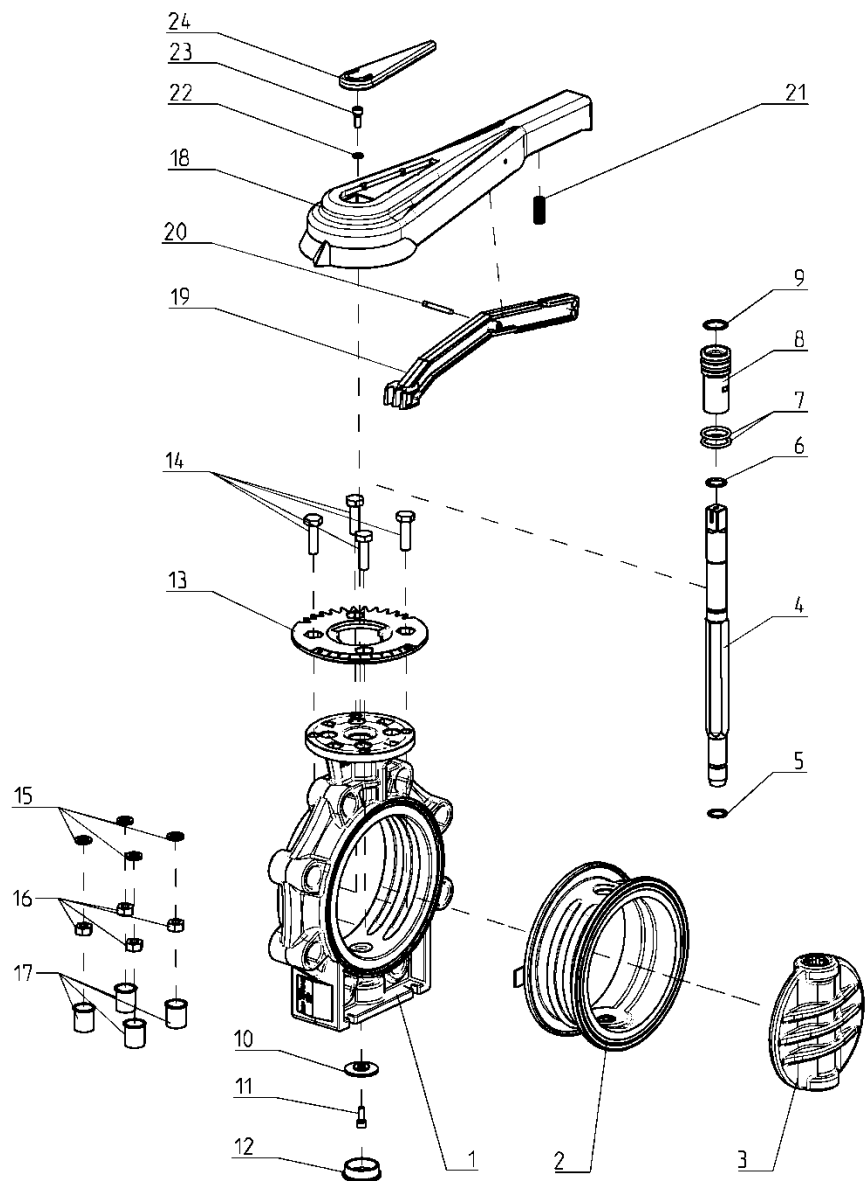

© Praher Plastics Austria GmbH DB/DE/18/08/202/D Subject to change without prior notice!

# Butterfly Valve K4 with hand lever



## Diagrams:

### Flow-characteristic

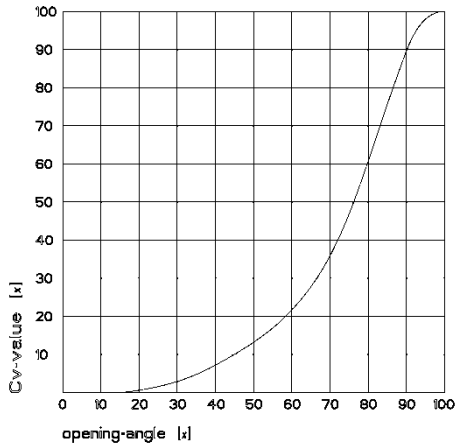

### Pressure – Temperature – Diagrams

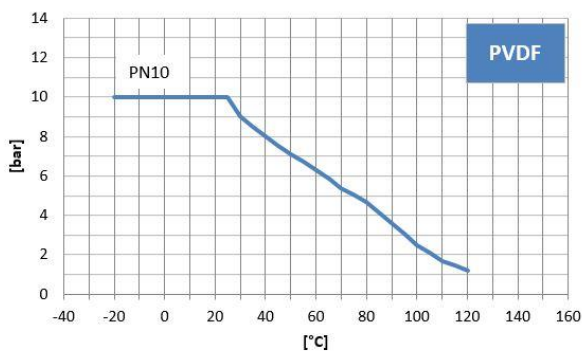
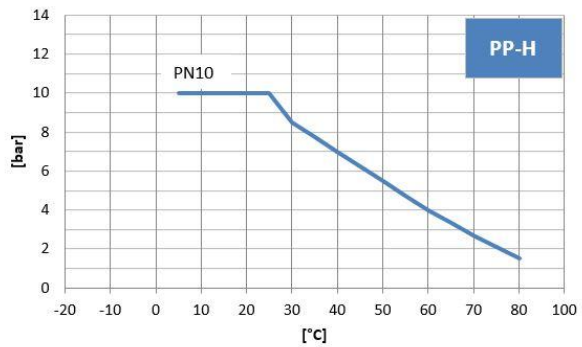
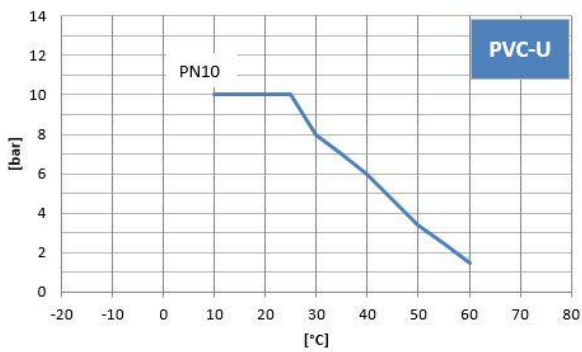

© Praher Plastics Austria GmbH DB/DE/18/08/202/D Subject to change without prior notice!



# Butterfly Valve K4 with hand lever



## Pressure loss–Diagram

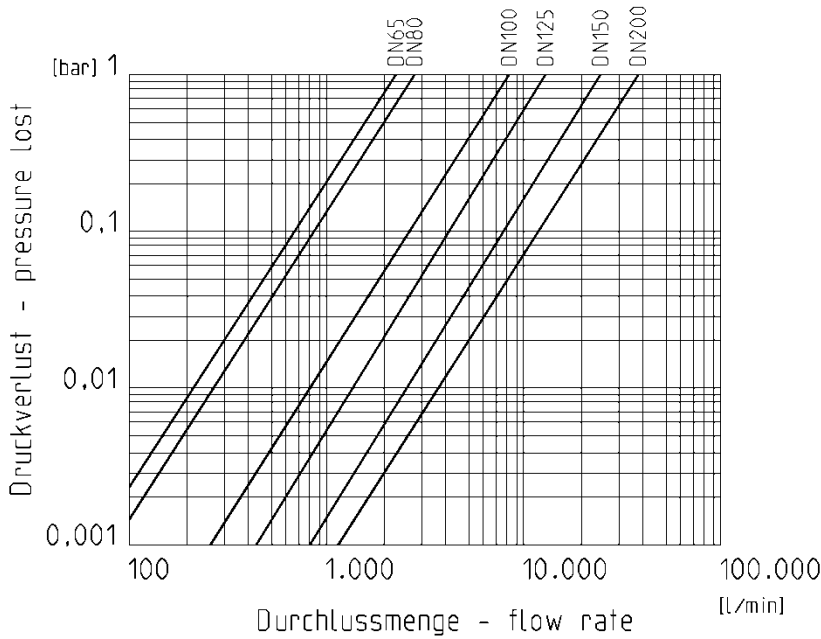

## Kv value

Pressure loss	DN65	DN80	DN100	DN125	DN150	DN200
0,001 bar	73 l/min	88 l/min	260 l/min	433 l/min	805 l/min	1200 l/min
1 bar	2300 l/min	2800 l/min	8200 l/min	13700 l/min	25500 l/min	38000 l/min

## Torque

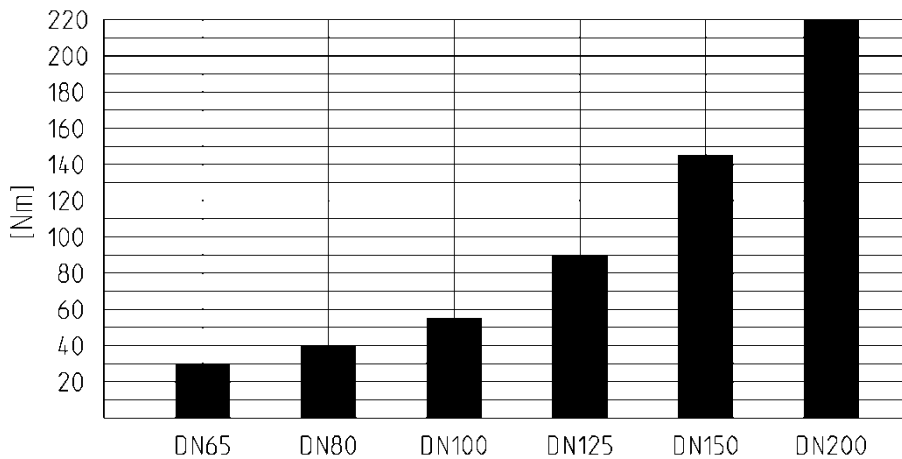

## Tightening torque of screws for flange connections

DN	65	80	100	125	150	200
Nm	15	18	20	30	40	55



+612 9615 9774

contact@mandalaypcf.com.au

www.mandalaypcf.com.au



## Butterfly Valve K4 with hand lever

### Installation in piping:

For a correct and complete opening of the flap, it is necessary that the used sockets and stub flanges have at least an inner diameter according to the table.

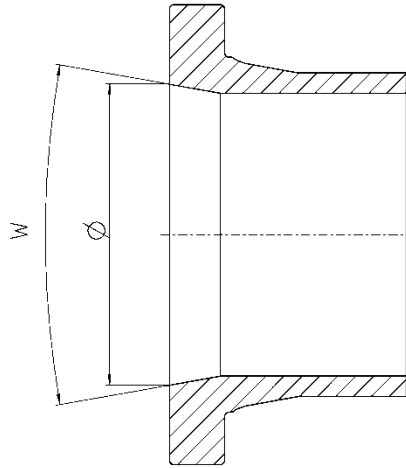

DN	d	Ø (mm)	w (°)
DN50*	d63*	60	40
DN65	d75	60	40
DN80	d90	77	40
DN100	d110	96,5	40
DN125	d140	121,5	40
DN150	d160	146,5	40
DN200	d225	203	40

\* Suitable only for **DIN** DN50 d63 sockets and stub flanges.