

Wafer check valve K4



Cross section: X-Ring / Quad - Ring



This document does not constitute a guarantee, it is for initial information purposes only. The product range is continually upgraded, the designs and types therefore only reflect the state of the art at the time of printing.
Subject to technical modifications!

General:

- Body material: PVC-U / PP
PPGF / PVDF
- Disc material: PVC-U / PP
PPGF / PVDF
- Sealing material: EPDM / FPM
- Dimensions: DN65 – DN250
d75 – d280
2 1/2" – 10"
- Standards: DIN 2501 PN10
ANSI B 16,5 Class 150
JIS B2220 10K
BS 10 table E*

*only for DN100 – DN250

Operating pressure:

- PVC PN10
- PP PN6
- PPGF
DN65 – DN200 PN10
DN250 PN8
- PVDF PN10

Adjusted springs and combinations of springs to operating pressure see page 5

Technical features:

- Excellent flow rates
- Disc opening up to 85°
- Non-wetted SS springs
- Included springs allow field settings for 3, 7 or 10 bar (see details page 5)
- Mounting link guide holes allow easy and quick installation between flanges
- No spacer required
- Available also without visual indicator and springs
- Horizontal and vertical installation possible
- Tight as of max. 0.3bar counterpressure

Wafer check valve K4

Dimensions:

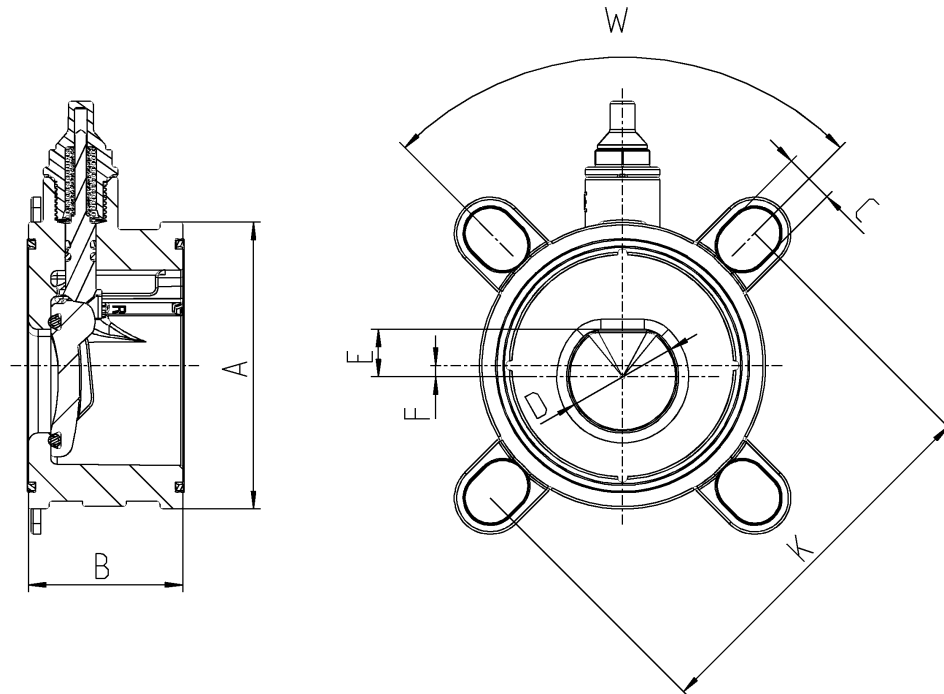

DN	65	80	100	150	200	250
d	75	90	110	160	225	280
A	115	128	155	212	264	325
B	63	71	80	106	140	140
C	20	20	20	20	24	27
K	139 - 145	150 - 160	175 - 191	234 - 242	290 - 299	350 - 362
W	90°	45°	45°	45°	45°	30°
D	45	53,5	76,5	113,5	149	186
E	19	24,5	32	44	62,5	77,5,
F	4,5	6	6	8	9	15

Dimensions in mm

© Praher Plastics Austria GmbH DB/DEEN/18/03/219/G Subject to technical modifications!

Wafer check valve K4

Exploded drawing:

Version with indicator and spring

- 01. Body
- 02. Disc
- 03. O-Ring disc
- 04. Fixing bolt left
- 05. Fixing bolt right
- 06. X-Ring body*
- 07. Indicator pin with O-Ring
- 08. Spring PN3
- 09. Spring PN7 | PN6 für PP
- 10. Cap transparent

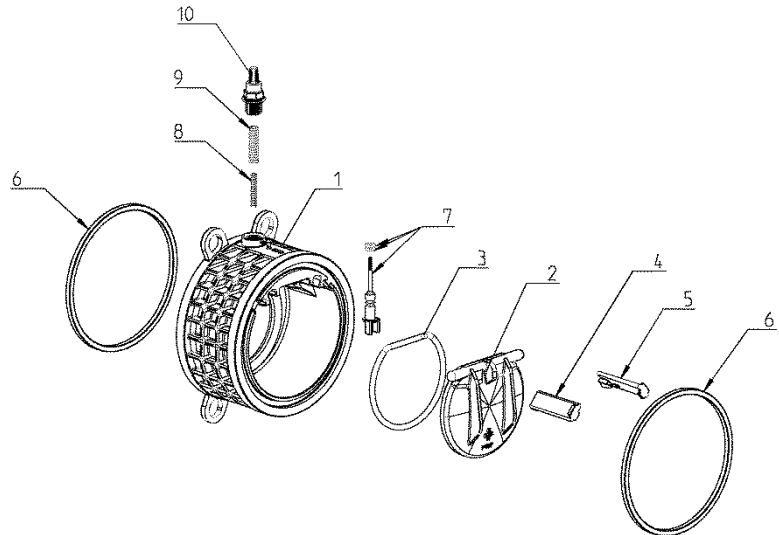

Version without indicator

- 01. Body
- 02. Disc
- 03. O-Ring disc
- 04. Fixing bolt left
- 05. Fixing bolt right
- 06. X-Ring body*
- 07. Plug with O-Ring
- 08. Cap black

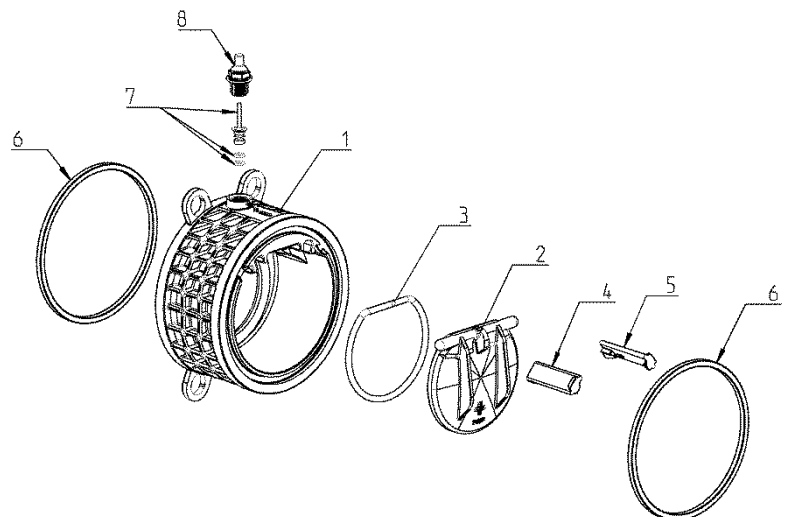

* the CVW K4 DN250 PVDF uses O- instead of X-Rings

Wafer check valve K4

Spares:

- | | |
|----------------------------|--|
| A. Flap Kit EPDM: | Disc with assembled O-Ring
Fixing bolt left
Fixing bolt right
X-Ring Body* |
| B. Flap Kit FPM: | Disc with assembled O-Ring
Fixing bolt left
Fixing bolt right
X-Ring Body* |
| C. O-Ring set EPDM: | O-Ring Disc
X-Ring Body*
O-Ring Indicator plug |
| D. O-Ring set FPM: | O-Ring Disc
X-Ring Body*
O-Ring Indicator plug |
| E. Indicator pin set EPDM: | Indicator plug with O-Ring
Spring PN3
Spring PN7 PN6 for PP
Cap transparent |
| F. Indicator pin set FPM: | Indicator plug with O-Ring
Spring PN3
Spring PN7 PN6 for PP
Cap transparent |
| G. Plug set EPDM: | Plug with O-Ring
Cap black |
| H. Plug set FPM: | Plug with O-Ring
Cap black |

* the CVW K4 DN250 PVDF uses O- instead of X-Rings

Wafer check valve K4



Diagrams:

Pressure – Temperature – Diagram

PVC

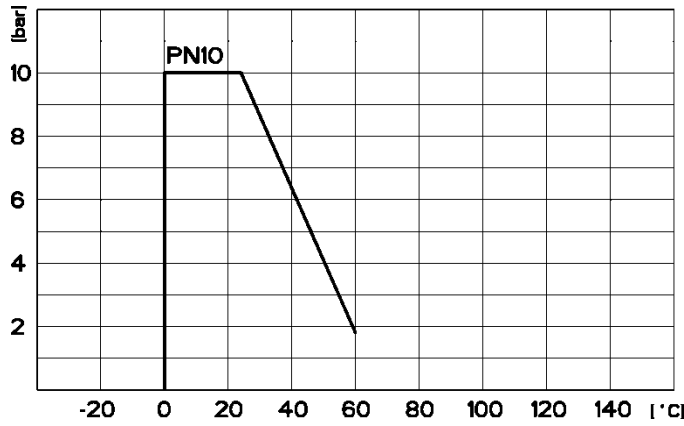

PP

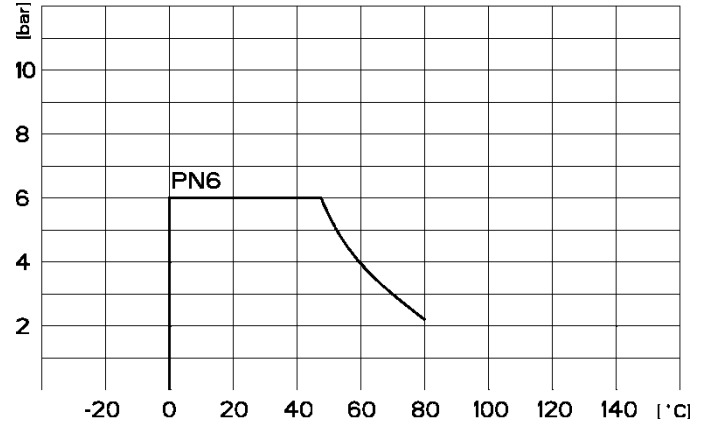

PPGF

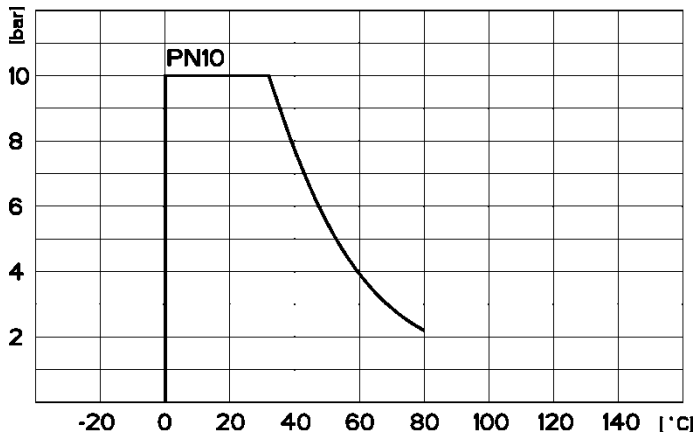

PVDF

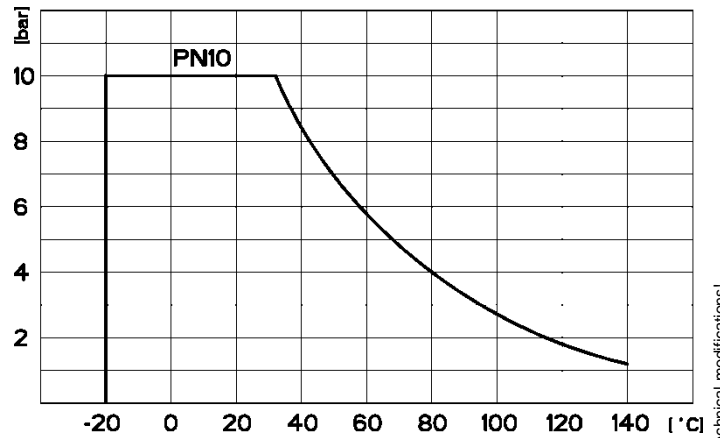

© Praher Plastics Austria GmbH DB/DEEN/18/03/219/G Subject to technical modifications!

Wafer check valve K4



Springs and combinations of springs

	spring 1	spring 2	spring 1&2
Operating pressure	3,1 – 7 bar	0,5 – 3 bar	7,1 – 10 bar

Example:
 Operating pressure 8 bar = combination of springs 1 & 2
 Operating pressure 6 bar = spring 1
 Operating pressure 2 bar = spring 2

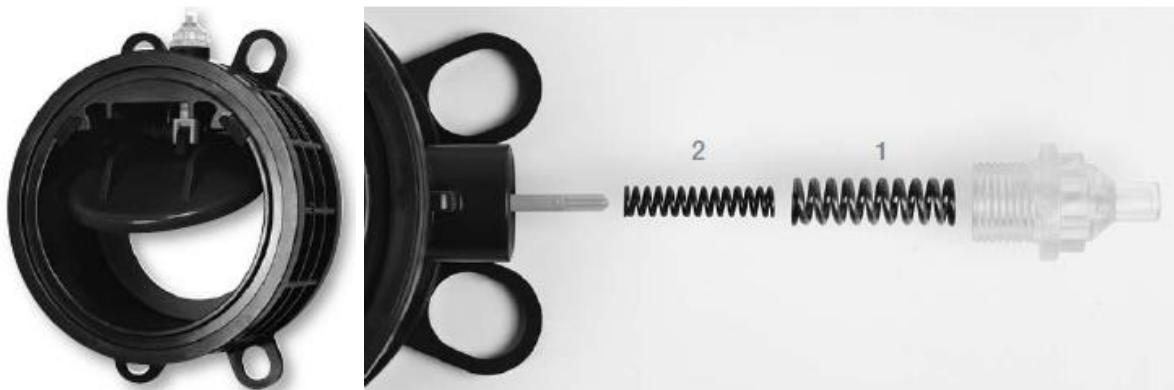

Pressure loss diagram

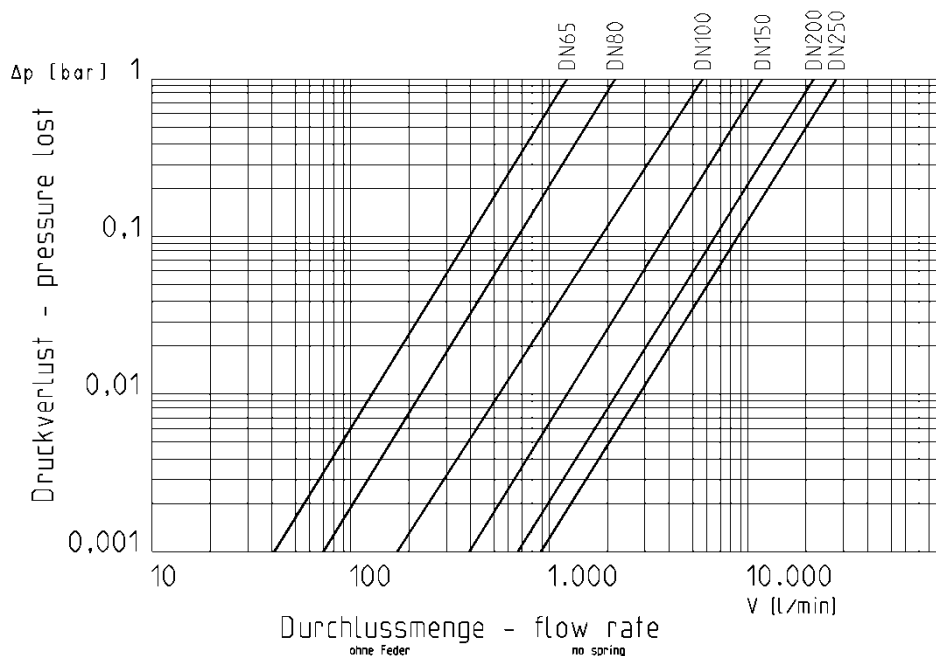

Wafer check valve K4

Cv value table

pressure loss	1 bar	0,001 bar
DN65	1.300 l/min	41 l/min
DN80	2.200 l/min	70 l/min
DN100	5.700 l/min	180 l/min
DN150	12.500 l/min	395 l/min
DN200	21.200 l/min	670 l/min
DN250	28.000 l/min	885 l/min

Values in pressure loss diagram obtained at maximum opening angle of 85°!

Opening pressure (without spring)

Dimension	Mounting position	
	horizontal	vertical
DN65	2,5 mbar	12,5 mbar
DN80	2,5 mbar	12,5 mbar
DN100	2,5 mbar	12,5 mbar
DN150	3 mbar	15 mbar
DN200	3,5 mbar	20 mbar
DN250	4 mbar	25 mbar

Opening pressure with spring is about 10 mbar higher!
Opening pressure is required differential pressure to open flap!

Tightening torque for connection flange

DN	65	80	100	150	200	250
Nm	15	18	20	40	55	60

Installation instructions:

The following must be noted when installing on a pump (pressure-side):

- No direct mounting on the pump flange or downstream bends or elbows
- A calming zone distance of 5x the DN nominal diameter must be planned before and after the wafer type check valve