

### pneumatic actuators

<b>Technical features</b>	<b>1</b>
<b>Elements list</b>	<b>2</b>
<b>Tables</b>	<b>3</b>
• torque	3
• dimensions	5
<b>Solenoids</b>	<b>6</b>
• options and regulation	6
<b>Declutchable gearboxes</b>	<b>7</b>

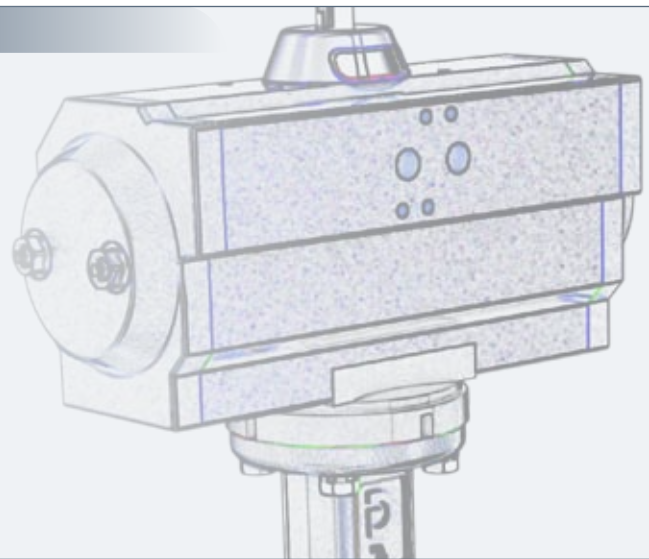

### electric actuators

<b>Actuators J+J</b>	<b>8</b>
• technical features	8
<b>Actuators Bernard</b>	<b>9</b>
• technical features	9
• electrical features tables	10
• dimensions tables	11
OA Series	11
AS Series 18÷80	12
AS Series 100÷1000	13
<b>Actuators GBN</b>	<b>14</b>
• technical features	14
• dimensions tables	15

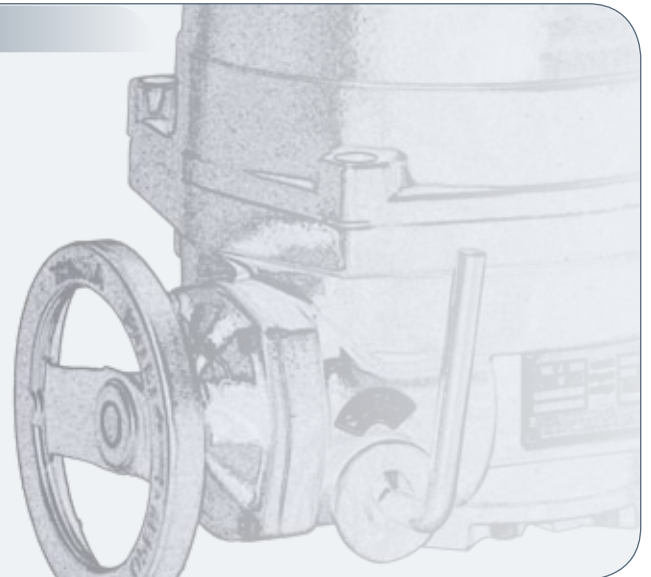

### hydraulic actuators

<b>Hydraulic ARES</b>	<b>16</b>
• technical features	16
• torque tables	17
• elements list	18
• dimensions tables	19
<b>Where we are</b>	<b>20</b>

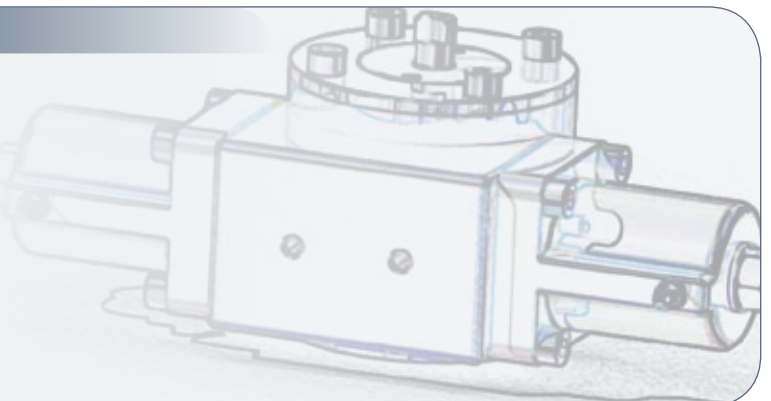

Hydraulic actuators - ARES type

Features:

- Compact design
- 90° rotation ±5°
- Travel adjustment in both direction of rotation
- Flange ISO 5211
- Double or single acting with spring return



Accessories

- Manual emergency control with decluchable override or hydraulic pump
- Limit switch boxes available with a wide range of switches and position transmitters
- Hydraulic circuits with solenoid valves, electro-hydraulic supply system, accumulator, etc..., for valve operation and control.

ARES - DA type - double acting

- Technical features:
  - » ductile iron cast body
  - » steel rack and pinion
  - » NBR seats
- fluid material:
  - » hydraulic oil type : HPL DIN51524-2 / ISO 6743-4. Viscosity 15/200 cst
- working pressure: 10 - 120 bar
- working temperature: -20°C / +80°C

No routine maintenance or lubrication is required.  
All movings parts are lubricated with heavy duty grease.

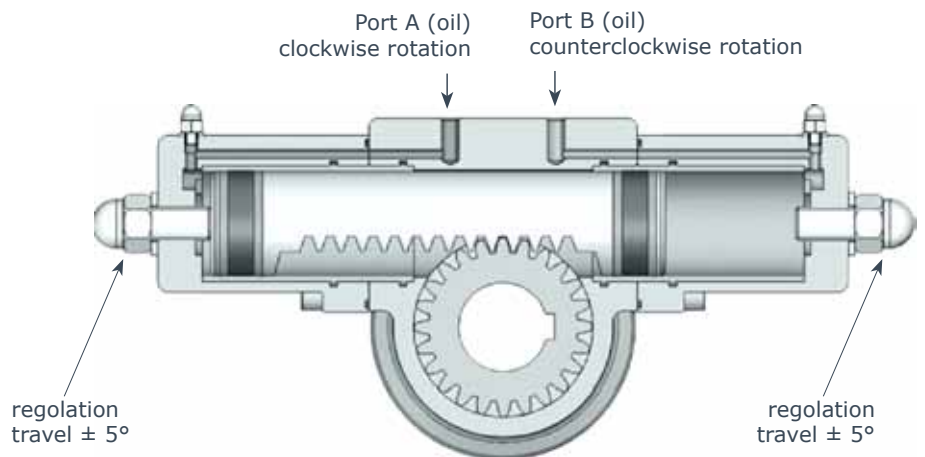

Torque hydraulic actuators double acting DA - Nm

TIPO/TYPER	10 Bar	20 Bar	30 Bar	40 Bar	50 Bar	60 Bar	70 Bar	80 Bar	90 Bar	100 Bar	110 Bar	120 Bar
ARES 28DA	19	38	57	74	93	112	129	148	167	185	203	221
ARES 40DA	40	80	110	150	190	230	260	300	340	380	410	450
ARES 50DA	80	150	230	310	380	460	530	610	690	760	840	920
ARES 63DA	150	300	460	610	760	910	1070	1220	1370	1520	1680	1830
ARES 80DA	260	530	790	1050	1320	1580	1840	2100	2370	2630	2890	3160

ARES - SR type - single acting

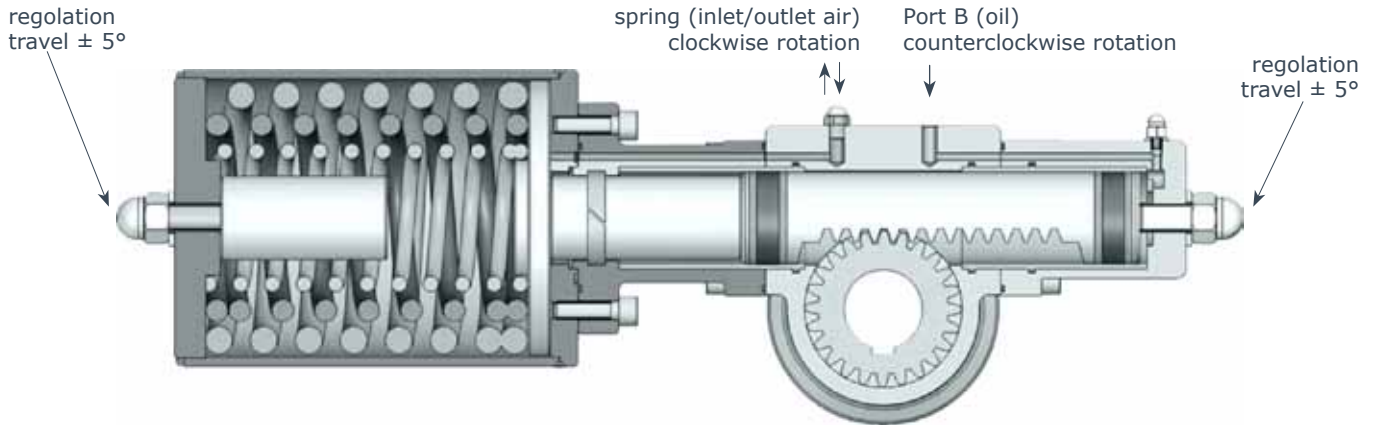

Single acting ARES actuators with spring return can be equipped with two different types of spring cartridges depending upon the torque required:

- » SRA with reduced thrust
- » SRB with the maximum thrust

The spring cartridge torque values are indicated in following tables.

Remarks: dimensioning the actuator please carefully select the spring cartridge because if it is necessary to modify the torque it is not possible to remove or add springs but it is necessary to substitute the complete cartridge.

Torque hydraulic actuators single acting SRA / SRB - Nm

type	spring cartridge	springs torque Nm		40 Bar		60 Bar		90 Bar		120 Bar	
		0°	90°	0°	90°	0°	90°	0°	90°	0°	90°
ARES 40SR	SRA	81	121	67	28	144	104	255	216	≈	≈
	SRB	162	242	≈	≈	≈	≈	175	96	288	208
ARES 50SR	SRA	164	243	143	64	294	215	523	443	--	--
	SRB	328	486	≈	≈	≈	≈	360	201	588	430
ARES 63SR	SRA	328	493	280	115	585	420	1035	873	≈	≈
	SRB	656	986	≈	≈	≈	≈	710	381	1170	840
ARES 80SR	SRA	560	840	486	207	1010	730	1804	1524	≈	≈
	SRB	1120	1680	≈	≈	≈	≈	1245	686	2020	1460

Hydraulic actuators - ARES type

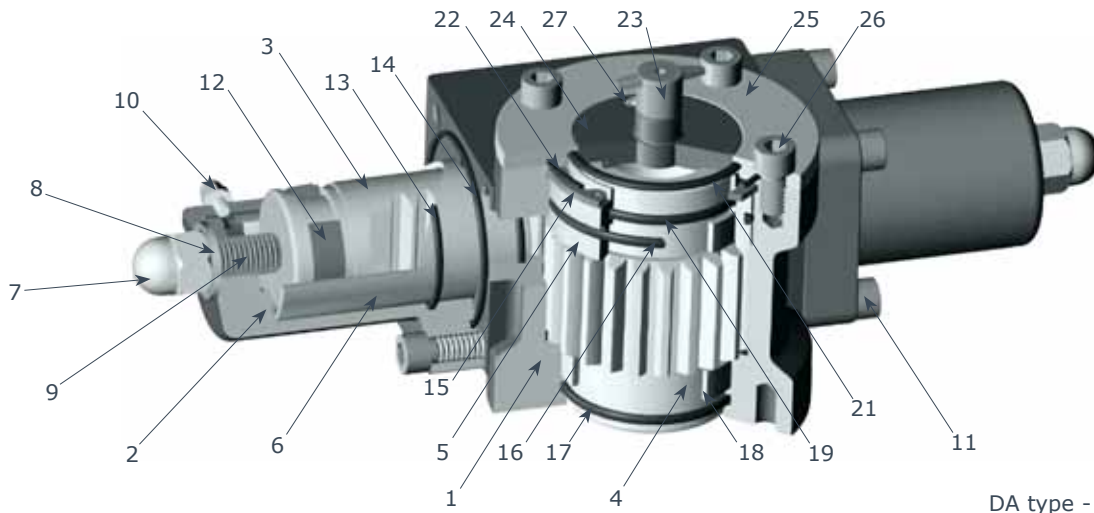

DA type - double acting

item	part	material	coating	q.ty DA	q.ty SR	item	part	material	coating	q.ty DA	q.ty SR
1	Body	Ductile iron	Epoxi coated	1	1	18	Lower pinion guide band	Reinforced POM	--	1	1
2	End cap	Ductile iron	Epoxi coated	2	1	19	O Ring	NBR	--	1	1
3	Piston rack	Steel	--	1	1	20	Upper pinion guide band	Reinforced POM	--	1	1
4	Pinion	Steel	--	1	1	21	O Ring	NBR	--	1	1
5	Pinion cap	Steel	--	1	1	22	O Ring	NBR	--	1	1
6	Cylinder	Steel	Lapped	2	2	23	Position indicator	Polyamide	--	1	1
7	Adjustement nut	Stainless steel	--	2	2	24	Position indicator flange	Aluminium	Anodized	1	1
8	Bleed nut	Steel + NBR	--	2	2	25	Upper flange	Aluminium	Anodized	1	1
9	Adjustement screw	Steel	--	2	1	26	Flange screw	Steel	--	4	4
10	Bleed screw	Steel	--	2	1	27	Flange screw	Steel	--	2	2
11	Endcap screw	Steel	--	8	8	28	Springs cartridge	Steel	Epoxi coated	--	1
12	Piston seal	Reinforced POM+NBR	--	2	2	29	Piston extension	Steel	Chromium plated	--	1
13	O Ring	NBR	--	4	3	30	O Ring	NBR	--	--	1
14	O Ring	NBR	--	2	2	31	Extension guide band	Reinforced POM	--	--	1
15	Snap ring	Steel	--	1	1	32	Springs cartridge bracket	Ductile iron	Epoxi coated	--	1
16	O Ring	NBR	--	1	1	33	Screw	Stee	--	--	4
17	O Ring	NBR	--	1	1						

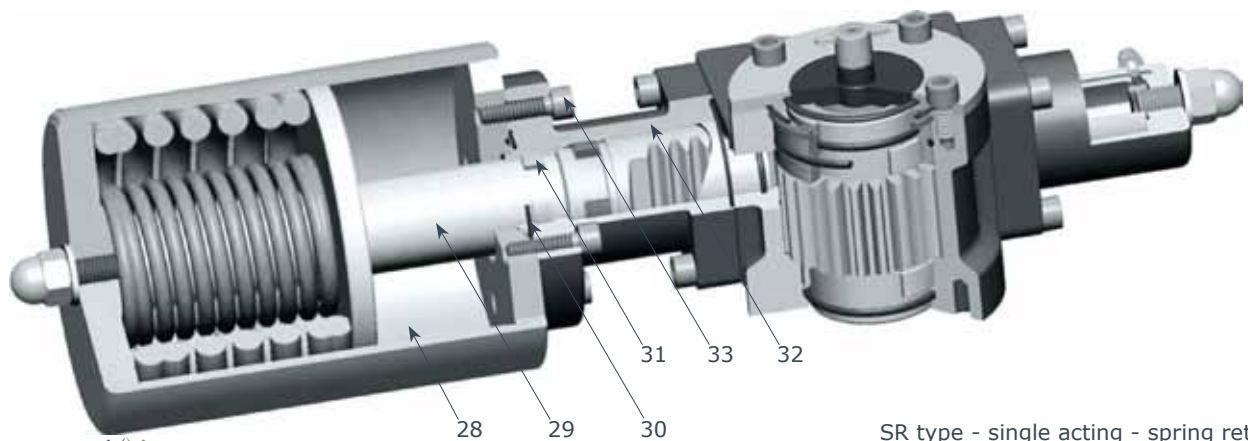

SR type - single acting - spring return

Hydraulic actuators - **ARES** type

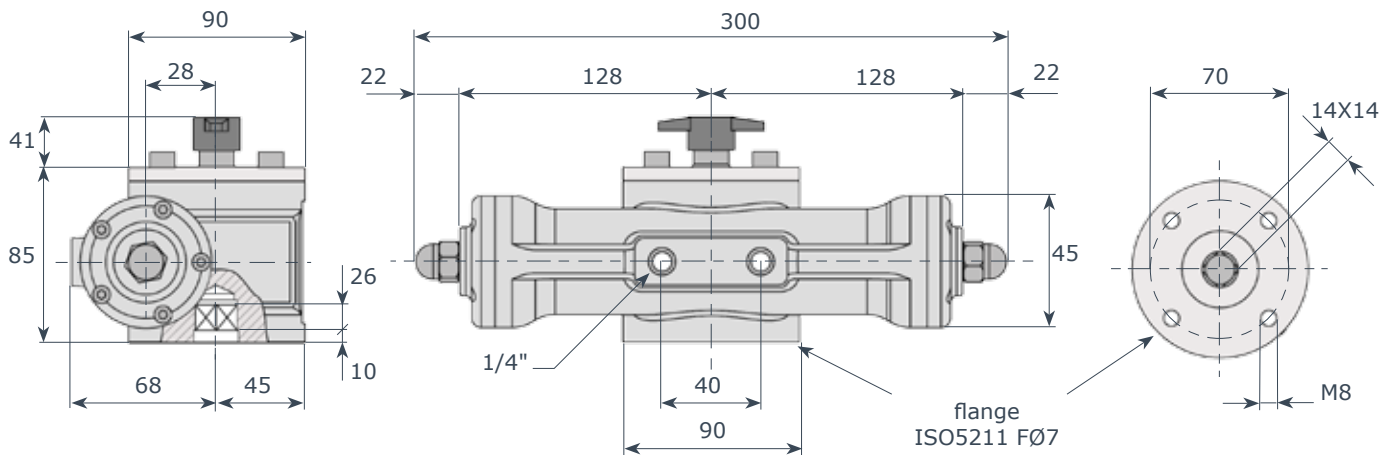

**ARES H 28 - DA** weight 8,5 Kg - volume 32 cmc

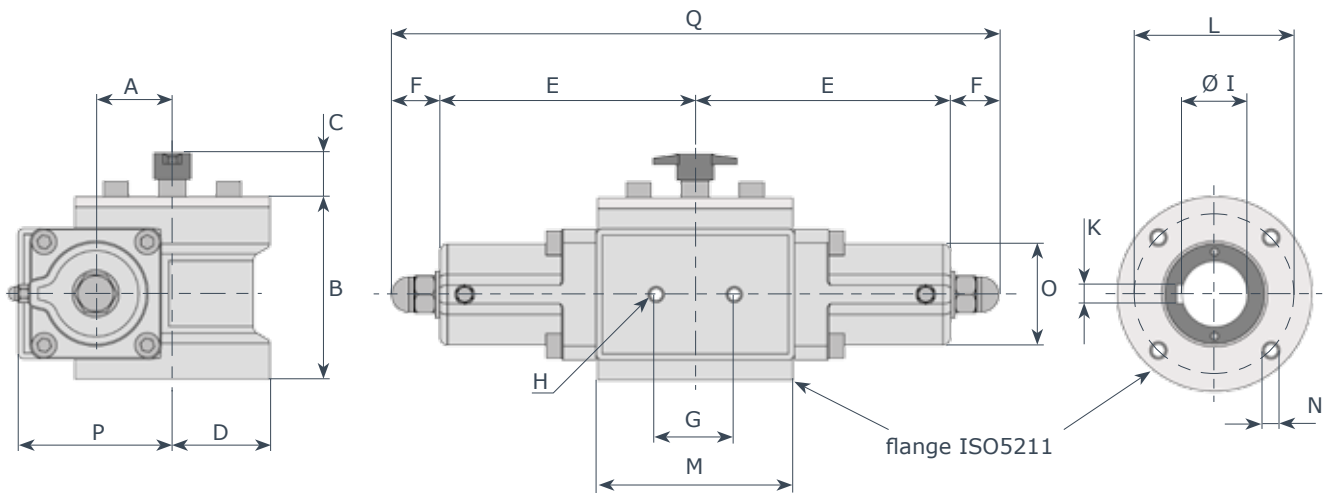

**ARES H 40 / H 50 / H 63 / H 80 DA**

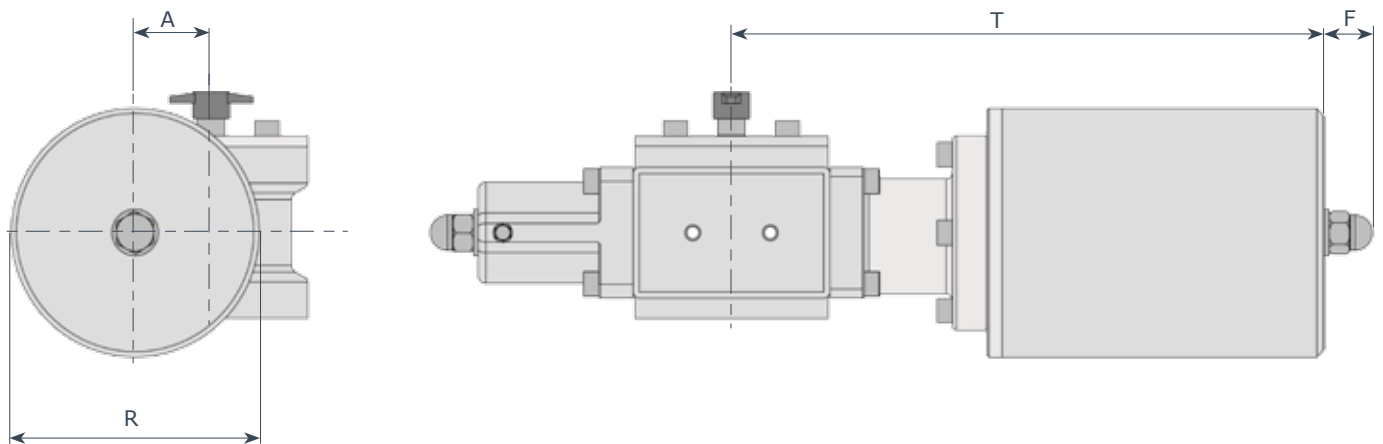

**ARES H 40 / H 50 / H 63 / H 80 SR**

mod	ISO 5211	A	B	C	D	E	F	G	H	Ø I	K	L	M	N	O	P	Q	R	T	DA Kg	SR Kg	vol. cm <sup>3</sup>
H 40	F07	40	102	41	45	143	30	50	1/4"	28	8	70	90	M8	55	85	346	140	325	12	29	59
H 50	F10	50	117	41	62.5	164	30	50	3/8"	42	12	102	125	M10	66	100	387	160	390	19	45	120
H 63	F12	63	127	41	75	201	40	50	3/8"	50	14	125	150	M12	80	125	482	210	545	30	75	239
H 80	F14	80	157	41	87.5	225	45	50	3/8"	60	18	140	175	M16	106	163	540	240	575	52	120	414