

Butterfly valve K4 Lug-Type with pneumatic actuator

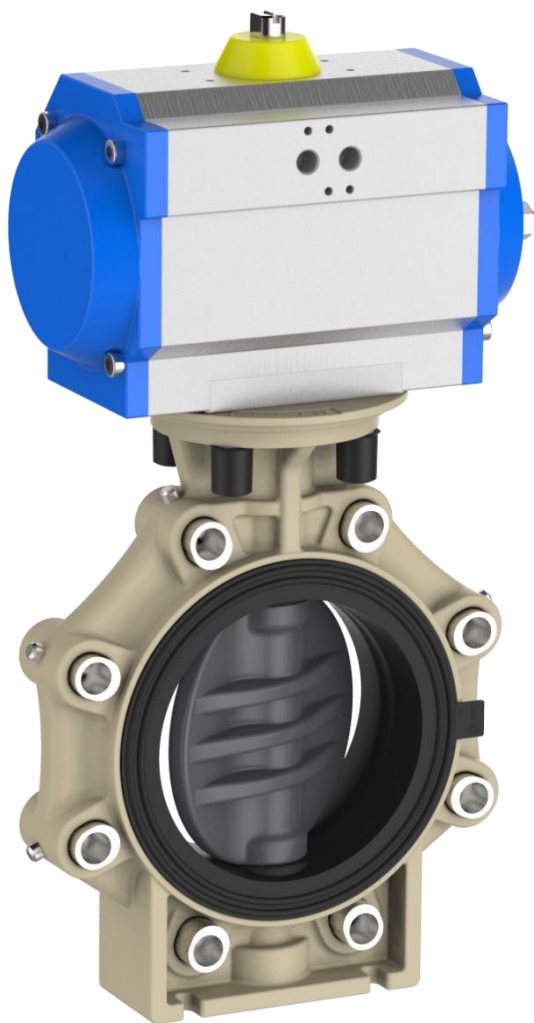

General:

- Sealing materials: EPDM, FPM
- Body material: PP-GF
- Flap material: PVC-C
- Dimensions: DN65 – DN100
d75 – d110
2 ½" – 4"
- Flange standards: DIN 2501 PN10
ANSI B 16,5 Class 150
- Additional dimensions: DN65/d63 PVC-U
DIN 2501 PN10
- Insert material: INOX A4
- Pin material: INOX A2

Operating pressure:

PVC-C

Used as intermediate butterfly valve: PN10

Technische Merkmale:

- only sleeve gasket and flap in touch with medium
- double sealed shaft
- integrated bracket for fix point mounting
- simple and quick assembling of the actuator without any extra parts
- If used as End-of-line valve a blind flange has to be mounted on the free connection side.
- Pressure has to be reduced if a flange is disassembled on one side
 - DN65 to DN125 → max. 6bar
 - DN150 to DN200 → max. 4bar

Only temporary usage

Material of actuator:

- Casing: anodised aluminium
- Casing cover: epoxy powder coated aluminium
- Screws/nuts: stainless steel

Ambient temperature: -20°C to +80°C

Control air: filtered air according to
PNEUROP/ISO class 4

Mounting position: any

Operation capacity/operation pressure:

- DA -> double acting / 5,5 to 10 bar
- SR -> single acting / 5,5 to 8 bar

Angel of rotation: 90°; travel limitation
adjustable on both sides -10° bis +10°

Mounting:

- Actuator – valve: ISO 5211
- Actuator – pilot valve: NAMUR (VDI/VDE3845)
- Actuator – feedback devices: NAMUR
(VDI/VDE3845)

Accessories:

- Limit switch box
- 3/2 and 5/2 ways pilot valve
- silencer

This document does not constitute a guarantee, it is for initial information purposes only. The product range is continually upgraded, the designs and types therefore only reflect the state of the art at the time of printing.
Subject to technical modifications!

Butterfly valve K4 Lug-Type with pneumatic actuator



Dimensions:

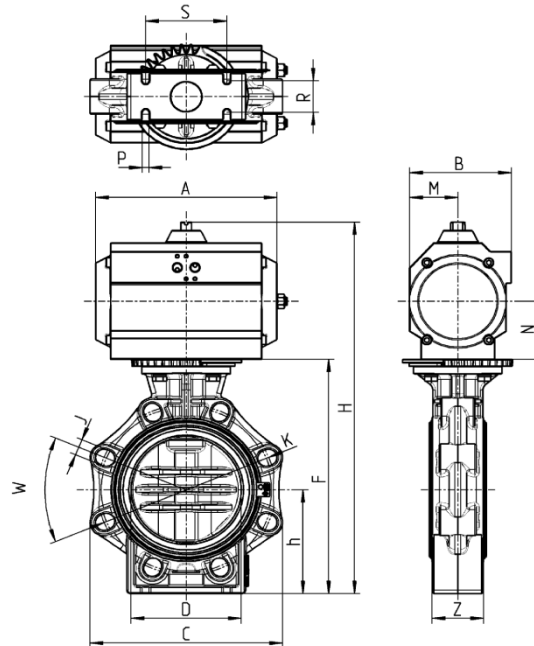

DN	65	80	100	
d	75	90	110	
G	2 1/2"	3"	4"	
W	90°	45°	45°	
J	19	19	19	
K	127 - 145	146 - 160	175 - 190,5	
K-DIN	145	160	180	
K-ANSI	139,7	152,4	190,5	
D	65	80	100	
C	133	176	206	
Z	46	49	56	
S	55	70	85	
R	25	30	35	
P	7	9	9	
h	100	100	115	
F	232	239	269	
Single acting	Actuator	UT-25 SR	UT-30 SR	UT-35 SR
	H	353	382	412
	A	239	230	246
	B	96	113	138
	N	63	70	87,5
Double acting	Actuator	UT-17 DA	UT-20 DA	UT-25 DA
	H	353	382	412
	A	197	177	239
	B	85	96	96
	N	48	60	63
M	36	43	43	

Dimensions in mm



Butterfly valve K4 Lug-Type with pneumatic actuator

Exploded drawing:

- 01. Body
- 02. Sleeve
- 03. Flap
- 04. Sealing shaft below
- 05. Shaft
- 06. Sealing shaft above
- 07. Sealing pilot bushing
- 08. Pilot bushing
- 09. Retaining ring
- 10. Holding disc
- 11. Screw
- 12. Cap
- 13. Cover plate
- 14. Tooth wheels
- 15. Screws
- 16. Caps
- 17. Inserts
- 18. Pins
- 19. Reducing sleeve
- 20. Pneumatic actuator

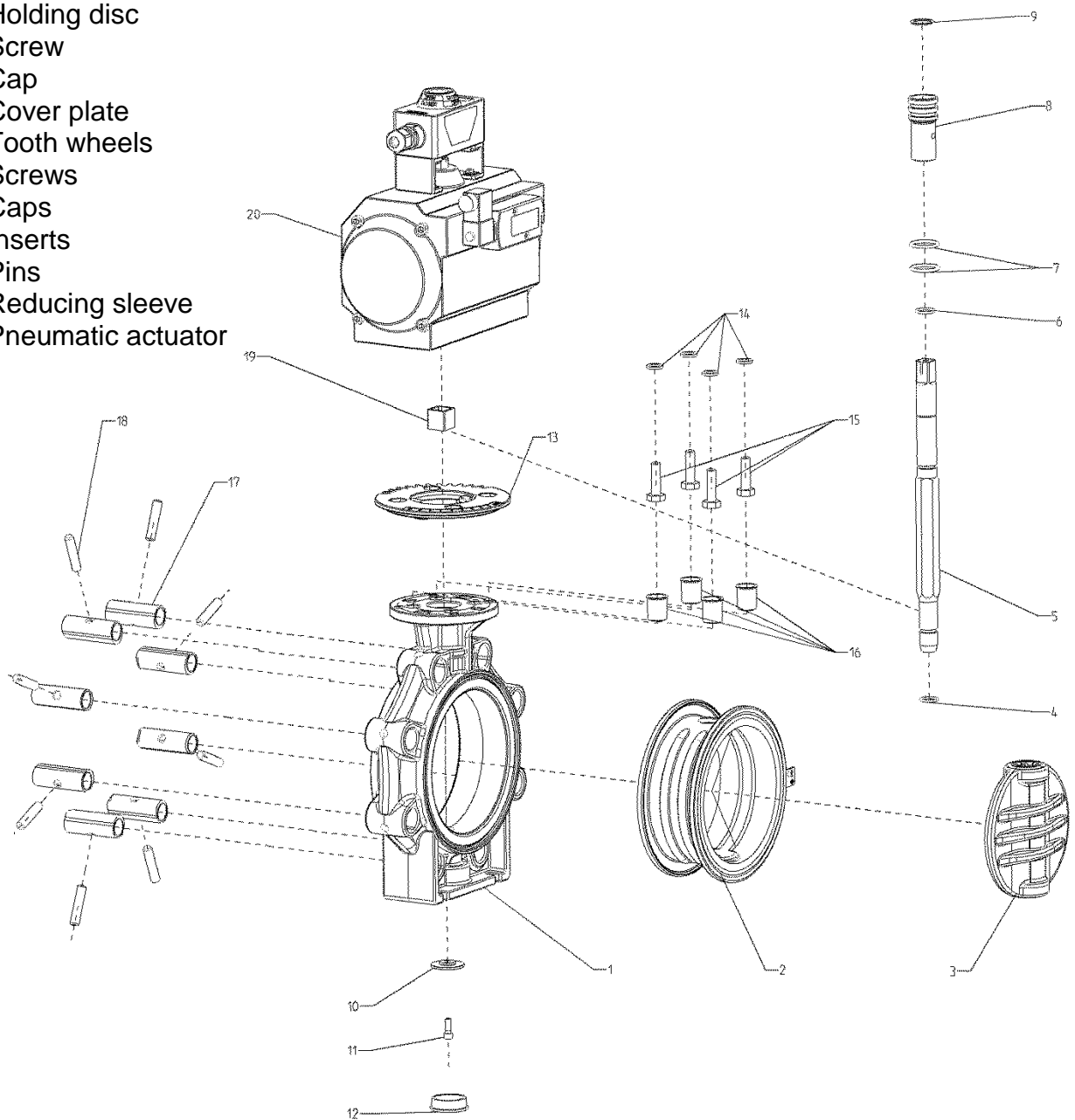

Butterfly valve K4 Lug-Type with pneumatic actuator



Diagrams:

Flow – characteristic

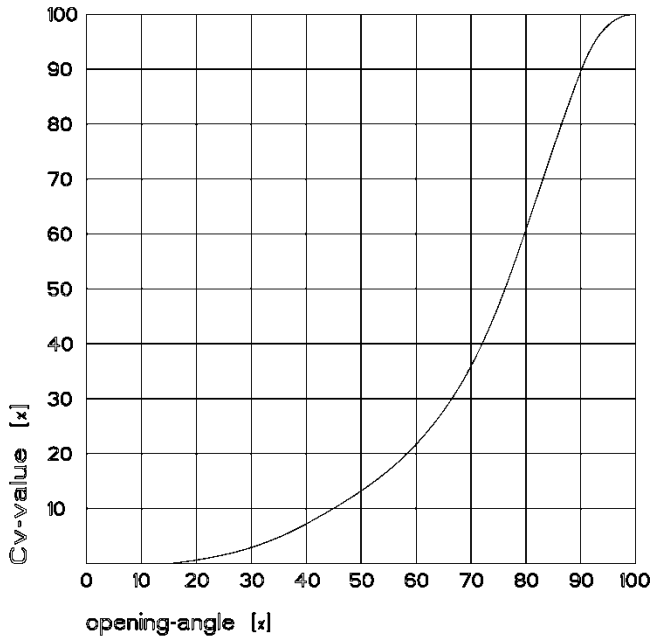

Pressure – temperature - diagram

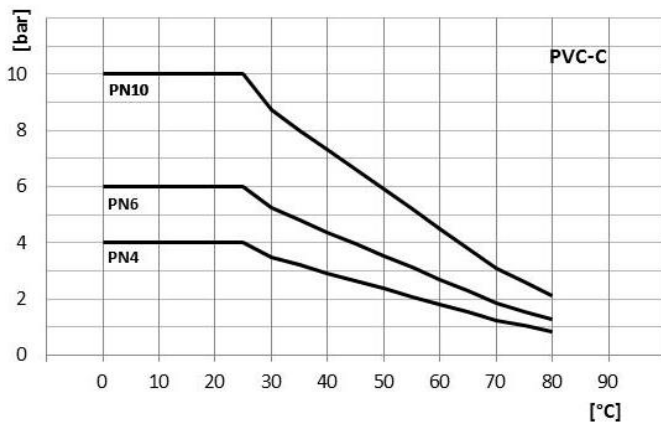

Butterfly valve K4 Lug-Type with pneumatic actuator



Pressure loss -diagram

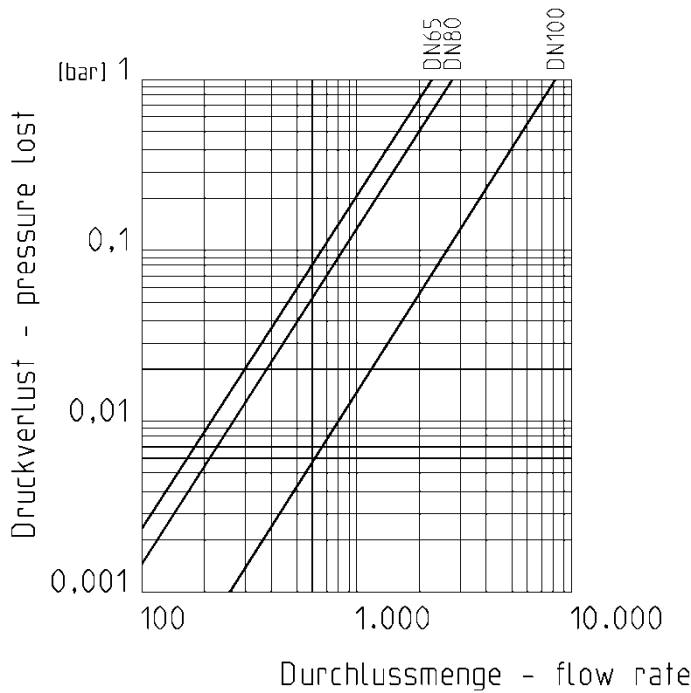

Cv value table

Pressure loss	DN65	DN80	DN100
0,001 bar	73 l/min	88 l/min	260 l/min
1 bar	2300 l/min	2800 l/min	8200 l/min

Torque

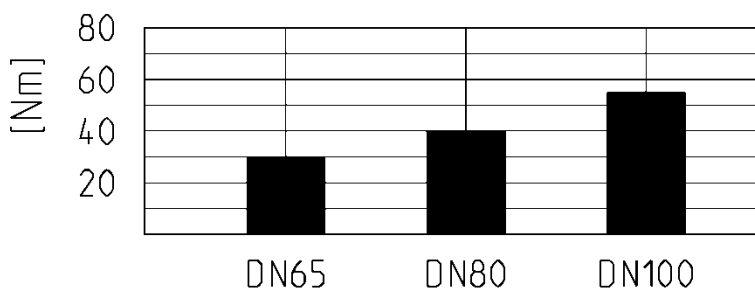

Tightening torque of screws for flange connections

DN	65	80	100
Nm	15	18	20



Butterfly valve K4 Lug-Type with pneumatic actuator

Installation in piping:

For a correct and complete opening of the flap, it is necessary that the used sockets and stub flanges have at least an inner diameter according to the table.

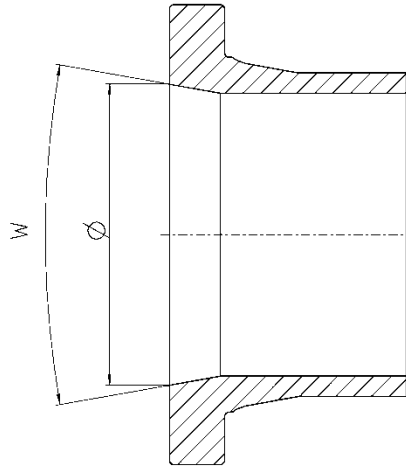

DN	d	Ø (mm)	w (°)
DN50*	d63*	60	40
DN65	d75	60	40
DN80	d90	77	40
DN100	d110	96,5	40

* Suitable only for **DIN** DN50 d63 sockets and stub flanges.

Butterfly valve K4 Lug-Type with pneumatic actuator

General installation instructions:

- Use suitable washers in accordance with DIN125A.

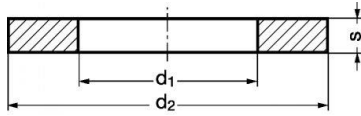

DN	65	80	100
Thread	M16	M16	M16
d1	17	17	17
d2	30	30	30
s	3	3	3

Dimensions in mm

- Adapt screw length to flange or stub flange.
- Check torque of screws on the opposite side, when one-side is removed (see torque of screws at flange connections).

Technical Data

CONTROL FUNCTIONS

SR SINGLE ACTING

AIR CONSUMPTION (FULL CYCLE)

Actuator	UT-25 SR	UT-30 SR	UT-35 SR
Norm dm ³	0,48	0,65	1,2

DA DOUBLE ACTING

AIR CONSUMPTION (FULL CYCLE)

Actuator	UT-17 DA	UT-20 DA	UT-25 DA
Norm dm ³	0,55	0,17	1,10

Butterfly valve K4 Lug-Type with pneumatic actuator



LIMIT SWITCH BOX

General:

- Limit switch box with two mechanical limit switches
- IP65 protected
- cable gland M20 x 1,5

Material:

- Casing: Polycarbonate black
- Casing cover: Polycarbonate with visual position indication
- Mounting brackets + screws: stainless steel
- Seals: EPDM

Voltage: 1 – 250 V AC/DC

Current:

- 16 A (250V AC)
- 2,5 A (24V DC)

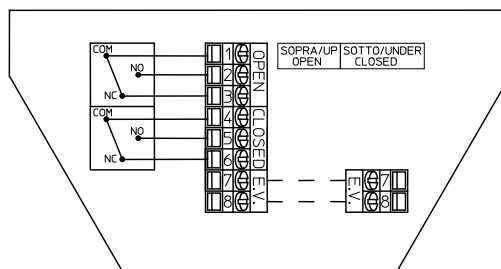

PILOT VALVE NAMUR

General:

- Solenoid valve NAMUR with combined 5/2- and 3/2-Wege function + standard coil
- easy change from 5/2- to 3/2-way-operation by adapter plates
- manual override as standard

Material:

- casing: anodised aluminium
- piston: aluminium
- sealing: NBR
- screws and spring: stainless steel

Current:

- 24 V DC (3W)
- 230 V AC (5VA)



5/2 FUNCTION

3/2 FUNCTION

