

Wafer type check valve K6 PVC



General:

- Material: PVC-U
- Seal materials: EPDM / FPM
- Dimensions: DN40 – DN350
d50 – d355
1 ½“ – 14“
- Flange standards: DIN 2501 – PN10
ANSI – class150
- Optional: with spring
- Mat. 1.4401 / AISI 316
- Hastelloy C-4 (on request)

Operating pressure:

- DN40 - DN200 MOP 10bar
- DN250 - DN300 MOP 8bar
- DN350 MOP 6bar

Pipe system:

- DIN PN6 und PN10
- ASTM SCH 40 & 80
(only SCH 40 possible for DN40 – DN50)
- PE100 SDR17
(Note installation information for stub flanges!)

Technical features:

- Spring can be retrofitted at any time without mechanical processing
- Operating temperature up to 60°C
- Tight as of max. 0.3bar counterpressure
- Novel valve design with conical sealing surface for highest of requirements and long service life
- Back-flushed shaft for prevention of deposits
- Easy to mount with screw centering for DIN2501 PN10 and ANSI class150
- Integrated mounting aid with defined breaking point for simple removal at dimensions DN40 to DN200
- Included assembly aid (eye bolt galvanized) at dimension DN250 and DN300
- No outlet aids required (optimized flap opening angle and improved CV value)
- Horizontal and vertical installation possible
- very good corrosion resistance

This document does not constitute a guarantee, it is for initial information purposes only. The product range is continually upgraded, the designs and types therefore only reflect the state of the art at the time of printing. Subject to technical modifications!

Wafer type check valve K6 PVC



Dimensions:

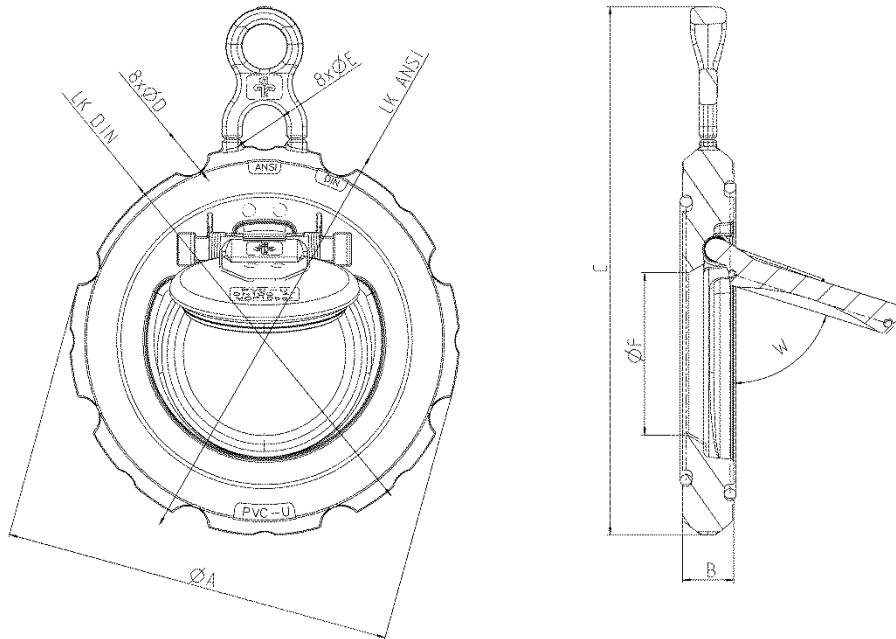

DN	40	50	65	80	100	125	150	200	250	300	350
d	50	63	75	90	110	140	160	225	280	315	355
ØA	95	109	130	146	175	198	223	280	343	406,4	447,6
B	16	18	20	20	23	25	30	34	42	47	51
C	141,8	159,5	185	200,4	237,2	262,3	288,8	348,3	-*	-*	-*
LK DIN	110	125	145	160	180	210	240	295	350	400	460
ØD	18	18	18	18	18	18	22	22	22	22	22
LK ANSI	98,5	120,65	139,7	152,4	190,5	215,9	241,3	298,45	361,95	431,8	476,25
ØE	15,5	19	19	19	19	22,2	22,2	22,2	25,4	25,4	28,6
ØF	23,5	33	42	53	73	93	110	150	186	229	261**

* because of included eye bolt galvanized instead of integrated mounting aid

Dimensions in mm

**Flow opening is pear-shaped. Area corresponds to ØF

Flap opening angle W with various pipe dimensions											
PVC PN10	91	88,5	82	84,5	72,5	73,5	69	74	74,5	66,5	69
PVC PN6	93,5	92,5	86	88,5	78	79	75	79	80	72	73
PVC schedule40	80,5	79,5	72	79,5	76	75	78,5	73	75,5	75	70
PVC schedule80	-	-	63	72	69	68	71	66	68,5	68,5	-
PE100 SDR17	88*	85,5*	78,5*	81,5*	68,5*	69,5*	64,5*	70*	71*	62*	66*

*note installation information

Dimensions in degrees



Wafer type check valve K6 PVC

Exploded drawing:

- 01. Body
- 02. Flap
- 03. Flap clip
- 04. O-Ring, flap
- 05. O-Ring, body frontside
- 06. O-Ring, body backside
- 07. Optional spring
- 08. Label

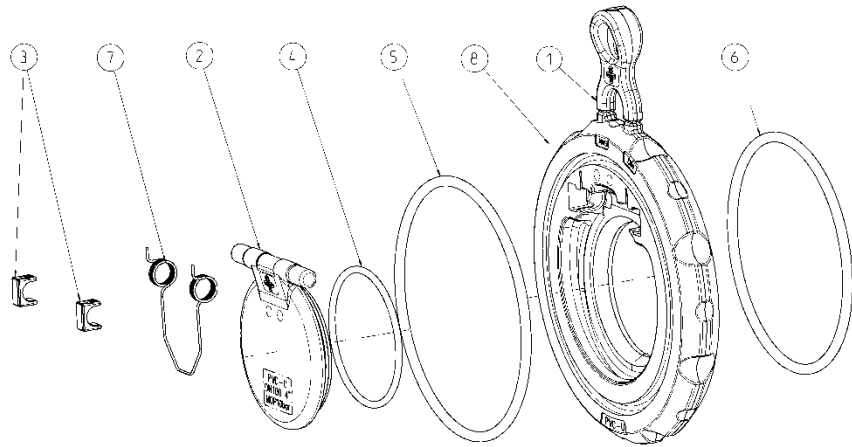

Spare parts:

- A. Flap Kit EPM: Flap with assembled O-Ring
Flap clips
O-Ring, body frontside
O-Ring, body backside
- B. Flap Kit EPDM: Flap with assembled O-Ring
Flap clips
O-Ring, body frontside
O-Ring, body backside
- C. O-Ring set EPDM: O-Ring, flap
O-Ring, body frontside
O-Ring, body backside
- D. O-Ringset FPM: O-Ring, flap
O-Ring, body frontside
O-Ring, body backside
- E. Spring: Spring
Label EPDM / FPM

Recommendation:

We recommend a replacement of all spare parts at the provided maintenance intervals.

Diagrams:

Pressure – temperature diagram

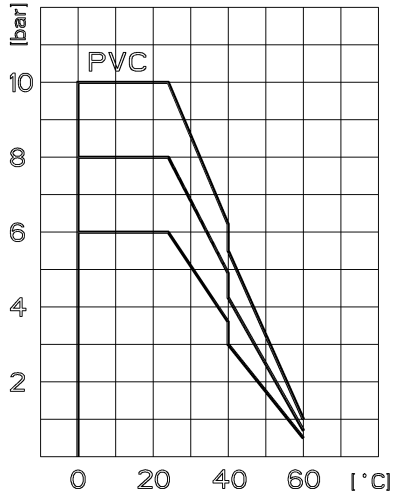

from 40°C increased safety factor

Pressure loss diagram

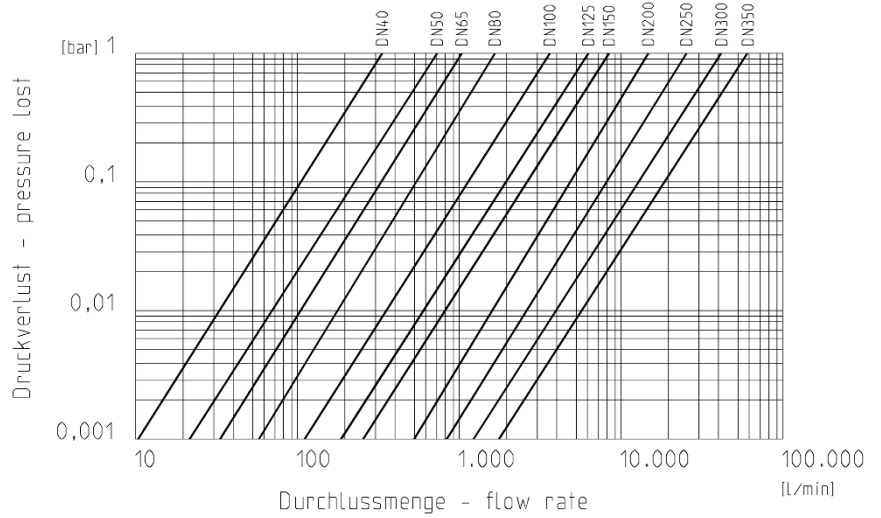

CV value table

Pressure lost	DN40	DN50	DN65	DN80	DN100	DN125	DN150	DN200	DN250	DN300	DN350
0,001 bar	10,5	22,1	33,2	55,3	114,9	191,9	259,8	497,5	816,8	1.301,8	1.839,4
1 bar	333	700	1.050	1.750	3.633	6.067	8.217	15.733	25.833	41.167	58.167

**Measurements implemented as per DIN EN 60534-2-3.
 Values in pressure loss diagram obtained at max. opening angle
 with PVC PN10 pipes and flow medium water at 20°C!**

Opening pressure (without spring)

Dimension	Mounting position	
	horizontal	vertikal
DN40	2 mbar	10 mbar
DN50	2 mbar	10 mbar
DN65	2 mbar	10 mbar
DN80	2 mbar	10 mbar
DN100	2 mbar	10 mbar
DN125	3 mbar	15 mbar
DN150	3 mbar	15 mbar
DN200	3 mbar	15 mbar
DN250	4 mbar	20 mbar
DN300	4 mbar	20 mbar
DN350	6 mbar	30 mbar

Opening pressure with spring is about 10 mbar higher!
Opening pressure is required differential pressure to open flap!

General installation information

- The valves are suitable for a horizontal and vertical installation
- Before mounting a wafer check valve K6 on a pipeline, we are recommending to carry out a completeness check, verify if any damages exist and if flap clips, seals and spring are correct positioned.
- To guarantee the optimum flap opening angle the stub flanges have to be centred at the body centre during the installation.
- After the installation the flap-clips have to be covered by the stub flanges (see picture).
- The supporting eyelet (in PVC-U for DN40 to DN200 and galvanised stainless steel for DN250 and DN300) will help during centering the valve and can be removed after completion of mounting procedure.
- No direct installation on pump flange or bend allowed.
- Before and after the wafer type check valve please provide a minimum stabilization zone of at least 5 times the nominal diameter (DN).

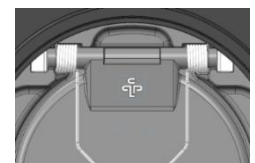

Cover Flap clip

Please note

- We do not recommend wafer type check valves without spring for turbulent flow conditions. For such applications the wafer type check valve with spring is best suitable.
- Flap-clips are meant for holding the flap in place and not as safety lock of the flap during transportation. Therefore the flap-clips may be loosen due to improper handling, storage and transportation. The correct positioning of flap clips, seals and spring has to be verified before mounting a wafer check valve K6 on a pipeline.

Wafer type check valve K6 PVC

Installation in PE100 SDR17 piping:

Stub flanges in PE100 SDR17 have to be chamfered. The following table indicates the measurements.

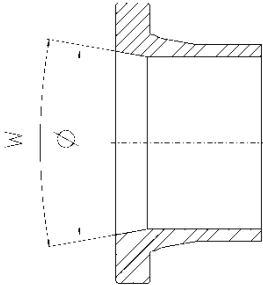

DN	40	50	65	80	100	125	150	200*	250*	300	350
Ø (in mm)	46	57	68	80	103	128	147	198	247	292	338
W (in Grad)	20	20	20	20	20	20	20	20	20	20	15

*no machining of the stub flange is required

Centering in the piping:

The wafer type check valve is centered in the piping via different screw recesses for DIN 2501 PN10 and ANSI class150 around the circumference of the body.

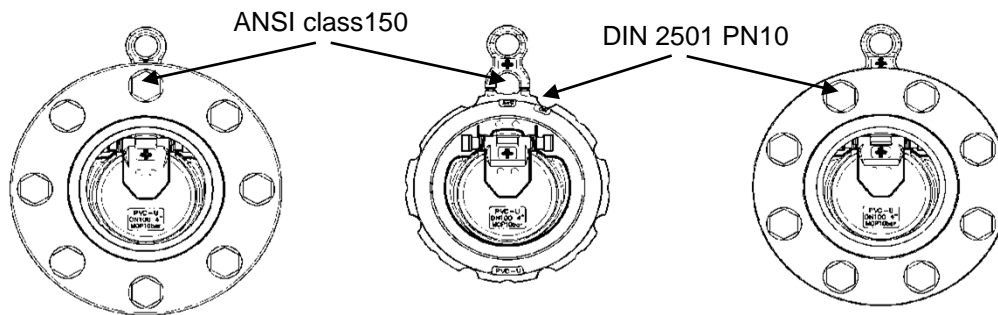

Tightening torque of screws for flange connections

DN	40	50	65	80	100	125	150	200	250	300	350
Nm	15	20	20	20	20	25	30	35	40	45	50

Bolts should be tightened in alternative diagonal sequence and with an equal torque

1. tighten the bolts by hand in order to ensure an equal alignment of the sealing surfaces
2. first, tighten the bolts to 50% of the recommended torque in alternative sequence (diagonal)
3. then, tighten the bolts further to 80% of the recommended torque in alternative sequence (diagonal)
4. finally, tighten the bolts to the recommended torque