

2 way ball valve M1 with Adapterset



General:

- Valve body material: PVC-U
- Sealing material: EPDM / FPM
- Ball seating: PTFE
- Dimensions: DN10 – DN80
d16 – d110
d3/8" – d4"

- Bracket material: PA-GFK
- Coupling material: PA-GFK

Connection types:

- Solvent socket DIN / ASTM

Other connection types on request

Operating pressure:

PVC DN10 – DN80 PN16

Technical features:

- Silicone free
- Buttress thread
- Double axial gasket
- Floating ball
- Double sided blocked ball
- Adjustable ball seating joint
- Integrated bottom mounting stand
- Radial installation or removal
- Maintenance free

Accessories :

- Clamping / spacing element

This document does not constitute a guarantee, it is for initial information purposes only. The product range is continually upgraded, the designs and types therefore only reflect the state of the art at the time of printing. Subject to technical modifications!

2 way ball valve M1 with Adapterset

Dimensions:

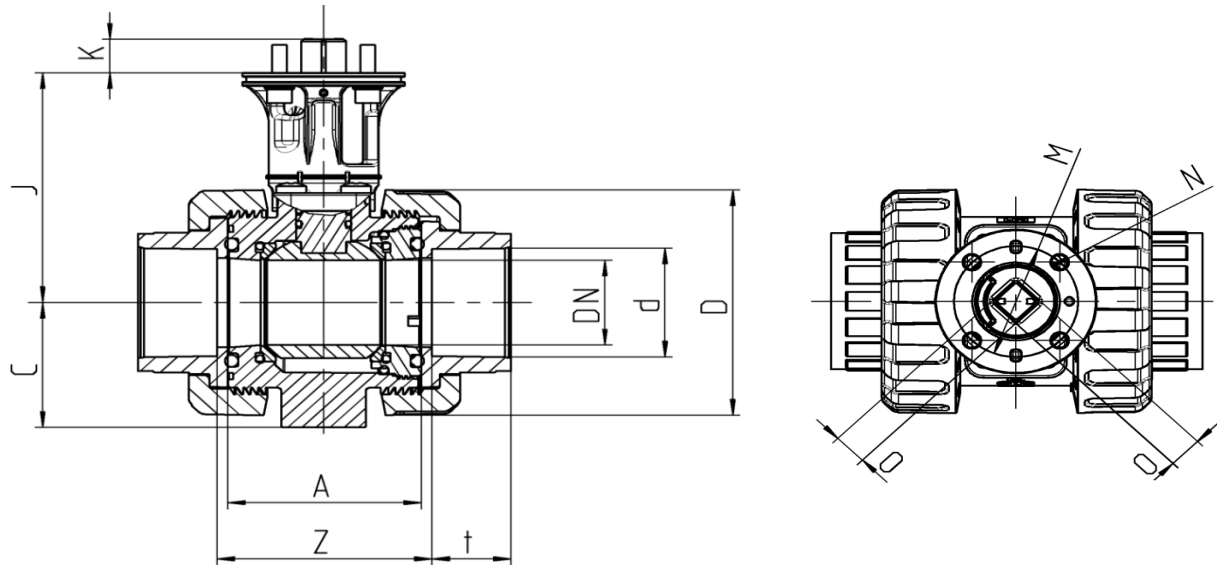

PVC-U

Connection types

PVC Solvent socket

DN	10	15	20	25	32	40	50	65	80	80
d	16	20	25	32	40	50	63	75	90	110
Flanschbild	F04	F04	F04	F04	F05	F05	F05	F07	F07	F07
A	45	45	53,5	54	62	78	87	111,5	135,5	135,5
C	33	33	40	43	51	56	64	85	100	100
D	55,5	55,5	62	70	84	101	115	149	182	182
J	80	80	85,5	88	97	103	109,5	136,5	159,5	159,5
K	11	11	11	11	15	15	15	18	18	18
M	42	42	42	42	50	50	50	70	70	70
N	5,5	5,5	5,5	5,5	6,5	6,5	6,5	8,5	8,5	8,5
O	11	11	11	11	11	14	14	17	17	17
t	16	16,5	19,5	23	26,5	31,5	38,5	44,5	56,5	61
Z	51	50	59,5	60	68,5	86	98	122	152,5	162
PN	16	16	16	16	16	16	16	16	16	16

Dimensions in mm

2 way ball valve M1 with Adapterset

Diagrams:

Pressure - temperature

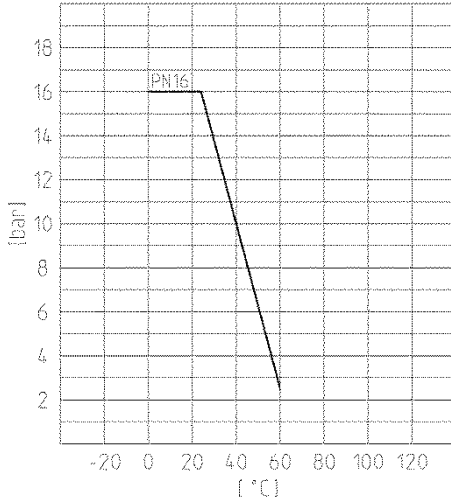

Pressure loss

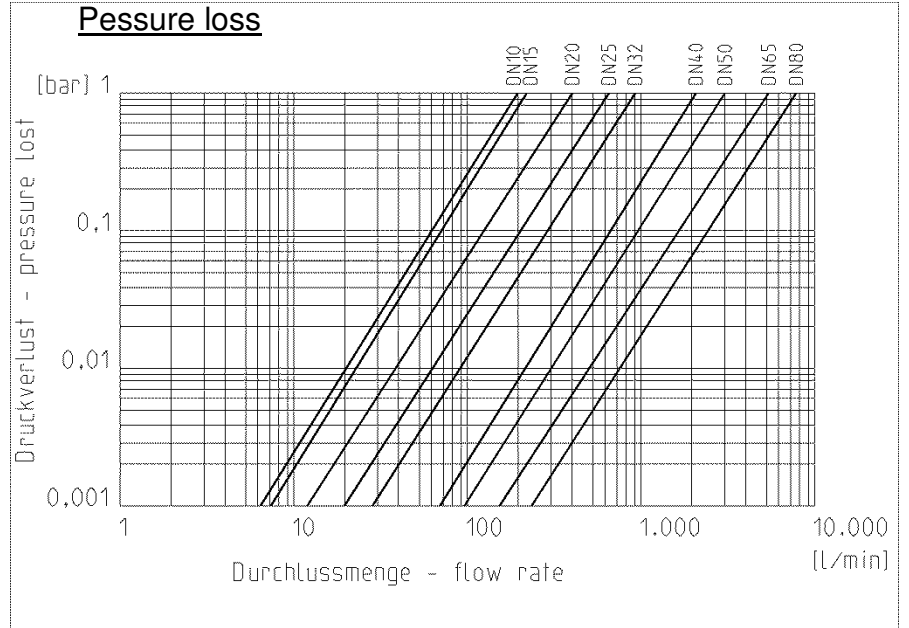

Cv value table

Druckverlust	DN10 d16	DN15 d20	DN20 d25	DN25 d32	DN32 d40	DN40 d50	DN50 d63	DN65 d75	DN80 d90	DN80 d110
0,001 bar	6,2	7,1	12,6	19,9	28,4	67	94,8	162,8	240,3	240,3
1 bar	198	225	400	630	900	2120	3000	5150	7600	7600

Angaben in l/min (PN16 Rohr)

Torque

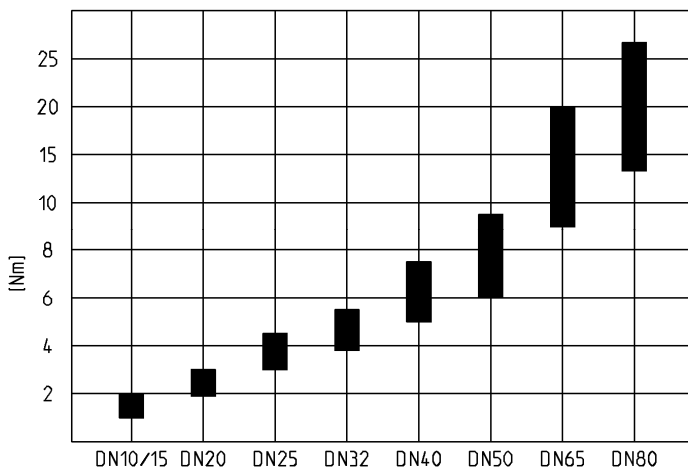

Flow characteristics

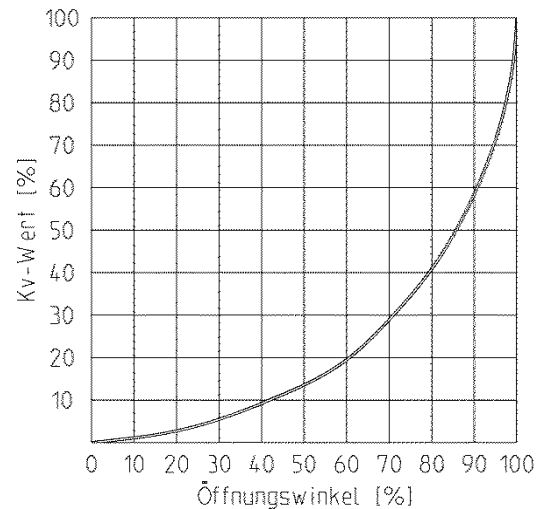

2 way ball valve M1 with Adapterset

Exploded drawing:

- 16. Bracket
- 17. Coupling – actuator
- 18. Screw
- 19. Hexagon socket screw
- 20. Toothed washer

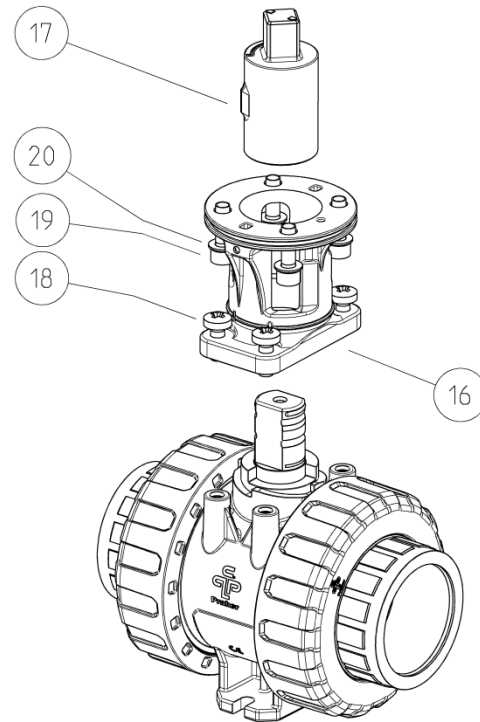

Bottom mounting stand – mounting possibilities:

- Assembly rail

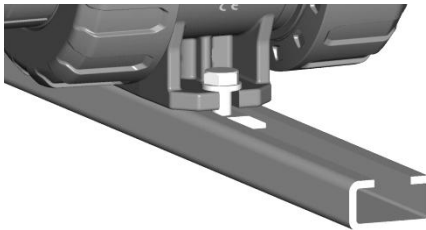

- Plate

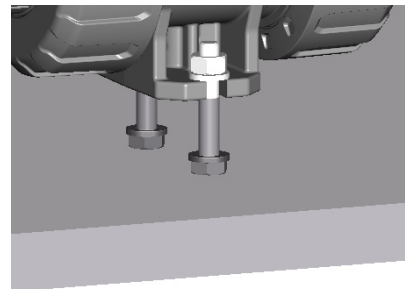

- Masonry / Concrete
 - Hanger screw and dowel required



2 way ball valve M1 with Adapterset

Accessories

Clamping / spacing element:

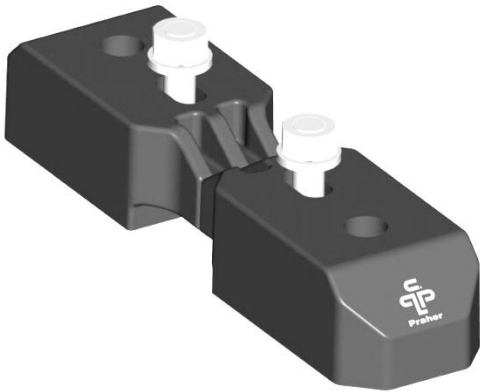

Technical features:

- Using for fixing as:
 - Clamping element
 - floors, walls, ceilings
 - plate
 - Spacing element
(screws additionally necessary)
 - for flange connection
- Bore for threaded bush

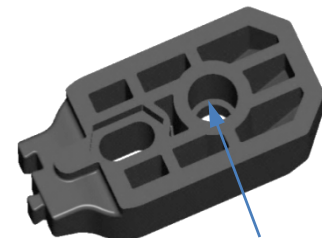
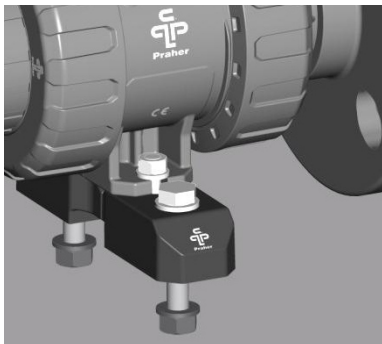

Bore for threaded bush

Dimensions:

Use as clamping
element

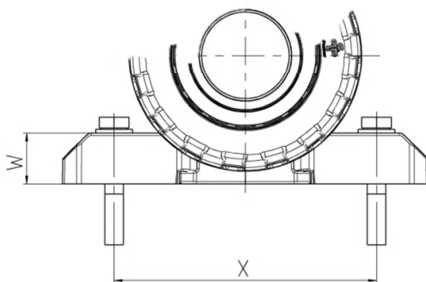

Use as spacing
element

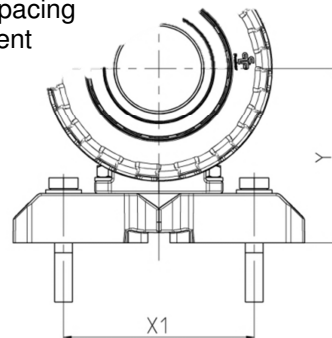

DN	10	15	20	25	32	40	50
d	16	20	25	32	40	50	63
T	54	54	54	65	65	65	65
U	25	25	25	32	32	32	32
V	6,5	6,5	6,5	8,5	8,5	8,5	8,5
W	16	16	16	22	22	22	22
X	90	90	94	107	109	114	119
X1	70	70	70	85	85	85	85
Y	49	49	56	65	73	78	86

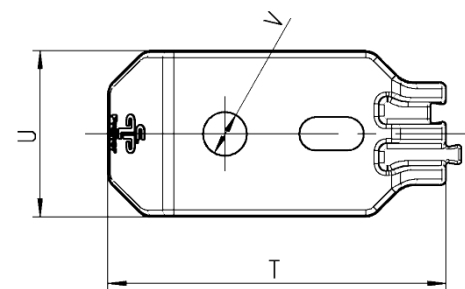

Dimensions in mm