

# PRESSURE REDUCING VALVE DMV 755

Nominal size DN 10–50

Nominal size 3/8"–2"

Nominal pressure PN 10 bar



## Features

- pressure setting range 1 to 9 bar
- control valve for reliable reduction of system pressures to constant operating pressures
- constant, low vibration control behavior
- high reproducibility of the set pressure
- pressure setting possible at any time, also during operation

## Additional options on request

- silicone free
- pressure presetting
- pressure gauge hole
- sealed
- NSF certification

[www.asv-stuebbe.com/produkte/mess-und-regeltechnik](http://www.asv-stuebbe.com/produkte/mess-und-regeltechnik)



# Pictogram Pressure Reducing Valve DMV 755

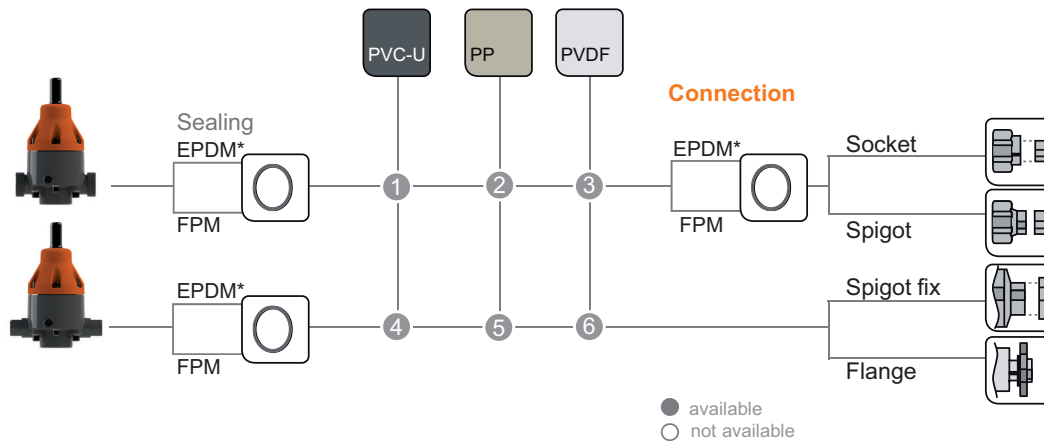

Diaphragm PTFE (EPDM)

**Pressure Gauge Installation**

Valves with 2 Threaded Holes G 1/4" incl. Plug



**Pressure setting range 1.0–9.0 bar**  
**Pressure settings in 0.5 bar steps**

**On Demand**

- » Sealing
- » Cleaning (Free of Surface Disturbing Substances)

\* EPDM-Seal in Combination with PVC-U resp. PP-Valve.

**Basic Nominal Sizes:**

DN 8	DN 10	DN 15	DN 20	DN 25	DN 32	DN 40	DN 50	DN 65	DN 80	DN 100	DN 125	DN 150	DN 200	DN 250	DN 300	DN 350	DN 400
------	-------	-------	-------	-------	-------	-------	-------	-------	-------	--------	--------	--------	--------	--------	--------	--------	--------

**Connection Material (process connection)**

<p><b>1</b> PVC-U socket <b>DIN, ANSI, BS, JIS</b> female thread Rp 1.4571 female thread Rp male thread R PE100 spigot <b>DIN</b> (95 mm)</p> <p><b>2</b> PP socket <b>DIN</b> female thread Rp PP spigot (IR)</p> <p><b>3</b> PVDF socket <b>DIN</b> PVDF spigot (IR)</p>	<p><b>4</b> PVC-U spigot fix PP/St. flange <b>DIN, ANSI</b> GFK flange <b>DIN</b></p> <p><b>5</b> PP spigot fix* PP/St. flange <b>DIN, ANSI</b> GFK flange <b>DIN</b></p> <p><b>6</b> PVDF spigot fix* PP/St. flange <b>DIN, ANSI</b></p> <p>* only for socket welding.</p>
--	---

## Pressure Reducing Valve DMV 755

### Use

- chemical plant engineering
- industrial plant engineering
- water treatment

### Application

- The pressure reducing valve which is directly controlled by the medium, is used in technical processing plants for reducing primary pressures to system dependent working pressures and for controlled maintenance of working pressures. Not suitable as equipment with safety function according to the pressure vessel directive.

### Valve function

- The opened valve is in equilibrium between the inlet pressure (primary side) and the lower working pressure (secondary side). If the working pressure goes above or below the desired value, the large area membrane is lifted against the spring force or pressed down by the spring force. The valve starts closing or opening until the equilibrium condition is reached again, i.e. the working pressure remains constant independent of an increasing or decreasing inlet pressure (as long as the inlet pressure > working pressure).

### Valve setting

- Set or adjust the desired or permissible working pressure at the adjustment screw with the aid of pressure gauges (ASV diaphragm pressure gauge guard, type MDM 902) in the pipe system after removing the protection cap.  
The adjustment screw is secured by a counter nut and can be sealed against unauthorized adjustment, if necessary.
- There is a differentiation between:  
secondary pressure - system closed or  
secondary pressure - system dynamically flowing

### Flow medium

- Technically pure, neutral and aggressive fluids, provided that the selected valve materials coming into contact with the media are resistant at the operating temperature according to the ASV resistance guide.

### Flow direction

- always in the direction of the arrow, see the „sectional drawing“ graphic

### ASV resistance guide

[www.asv-stuebbe.de/pdf\\_resistance/300051.pdf](http://www.asv-stuebbe.de/pdf_resistance/300051.pdf)

### Process temperature

- See the „pressure/temperature diagram“ graphic

### Process pressure

- See the „pressure/temperature diagram“ graphic

### Nominal pressure (H<sub>2</sub>O, 20 °C)

- PN 10 bar

### Size

- DN 10–50

### Pressure setting range

- 1–9 bar

### Working pressure

- set pressure minus flow dependent pressure reduction (see characteristic curves):  
secondary pressure 1–9 bar

### Constant working pressure

- Difference between the maximum and minimum secondary pressure, caused by primary pressure fluctuations: approx. ± 0.2 bar

### Hysteresis

- Difference between opening and closing pressure approx. 0.1–0.4 bar

### Actuation

- medium controlled

### Device connection

- see graphics  
„Pictograph, pressure reduction valve DMV 755“

## Material with medium contact

Housing:

- PVC-U, PP, PVDF

bonnet:

- PP, glass fiber reinforced

Diaphragm:

- PTFE

(EPDM diaphragm, PTFE-coated on the medium side)

Sealing:

- FPM, EPDM

## Material without medium contact

Screws:

- stainless steel (1.4301)

## Mounting position

- as required

## Fastening

- via threaded inserts (metal inserts) in the valve body

## Color

- bonnet: orange, RAL 2004
- bottom section: PVC-U, gray, RAL 7011
- bottom section: PP, gray, RAL 7032
- bottom section: PVDF, opaque, yellowish-white

## Pressure gauge connection

- The pressure reducing valves can be factory fitted with a pressure gauge for neutral media. The resistance of the pressure gauge material has to be taken into consideration for other medium types.

## Pressure gauge preparation

- Housing holes on both ends G 1/4" incl. plug

## Pressure gauge

- Chemical version, damped
- Chemical version, not damped
- Contact pressure gauge

## Pressure/temperature diagram

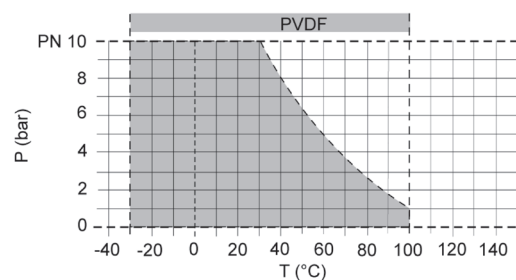
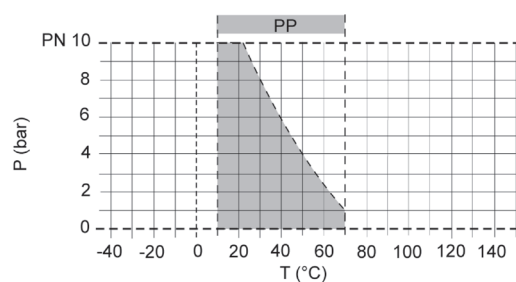
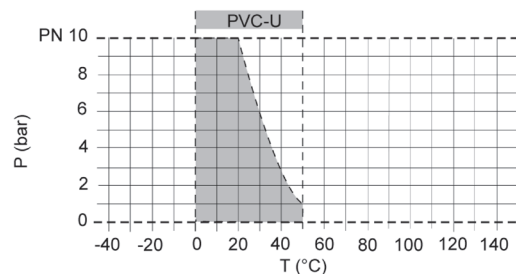

Description	
P	Operating pressure
T	Temperature

The pressure/temperature limits of the materials are valid for the stated nominal pressures and a service life of 25 years. These values are guide values for flow medium types which do not negatively impact the physical and chemical characteristics of the valve material. It may be necessary to take diminution factors into consideration. The durability of wear parts depends on the operating conditions of the application.

# Pressure Reducing Valve DMV 755

## Operating behavior

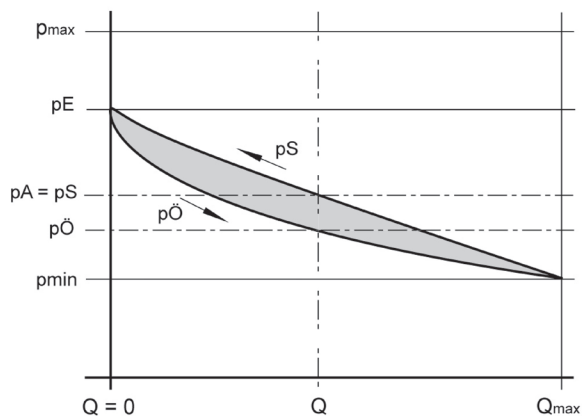

	Description
pE	set pressure
pA	Working pressure
p <sub>max</sub>	maximum pressure
p <sub>min</sub>	minimum pressure
p <sub>O</sub>	opening pressure
p <sub>S</sub>	closing pressure
p <sub>O</sub> -p <sub>S</sub>	hysteresis
p <sub>A</sub> -p <sub>E</sub>	flow dependent pressure reduction
Q	Flow

## Characteristic curve, design example

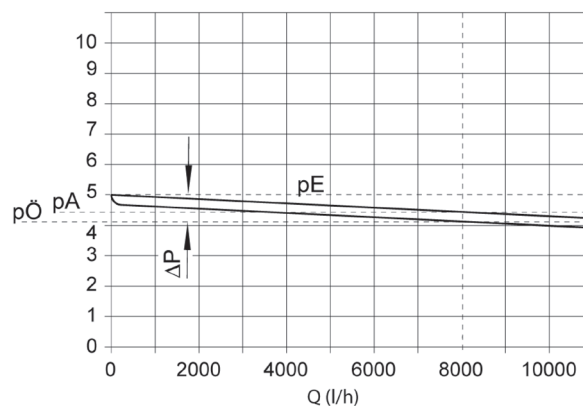

The valve is set tight at 5 bar.  
 Desired flow rate 8000 l/h, medium H<sub>2</sub>O.  
 According to the curve, this results in the following values:  
 Set pressure pE: 5 bar  
 pressure reduction: 0.8 bar  
 working pressure pA: 4.4 bar

	Description
pA	Working pressure
pE	set pressure
p <sub>O</sub>	opening pressure
Δp	Pressure loss
Q	Flow

## Characteristic curve, set range

### DN 10

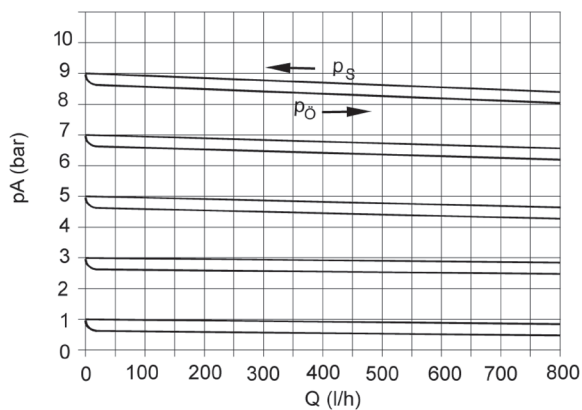

# Pressure Reducing Valve DMV 755

**DN 15**

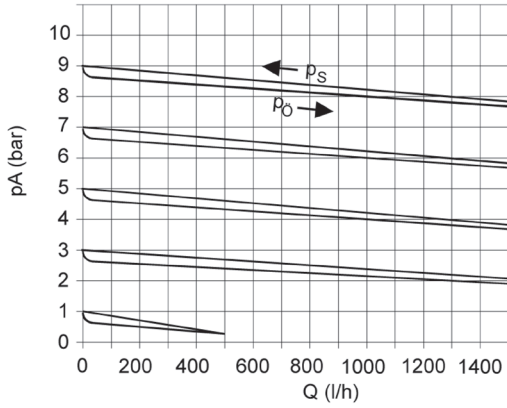

**DN 32**

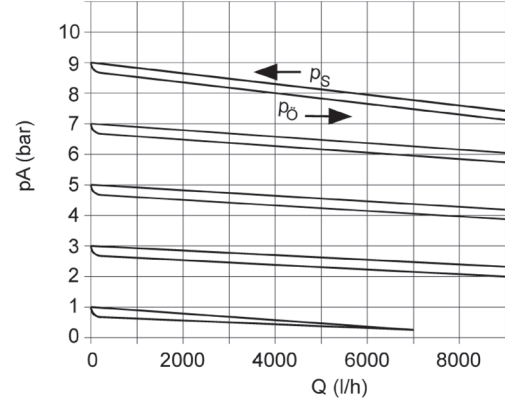

**DN 20**

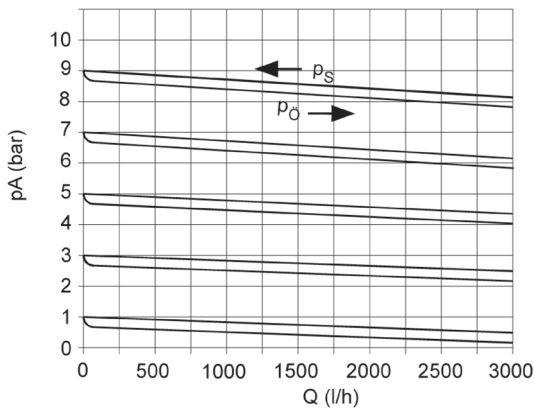

**DN 40**

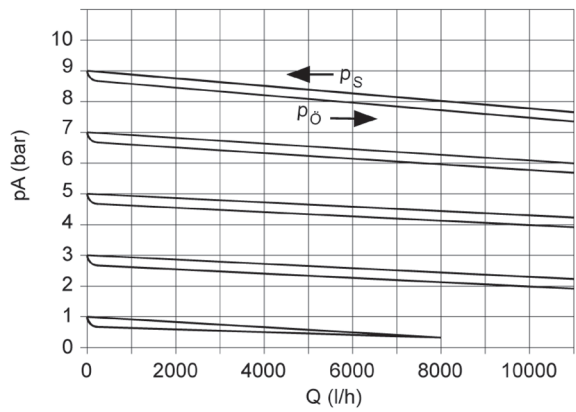

**DN 25**

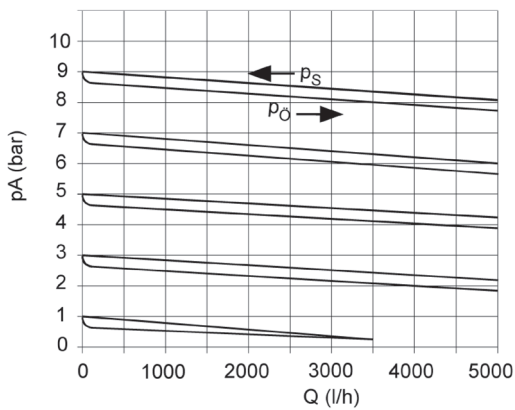

**DN 50**

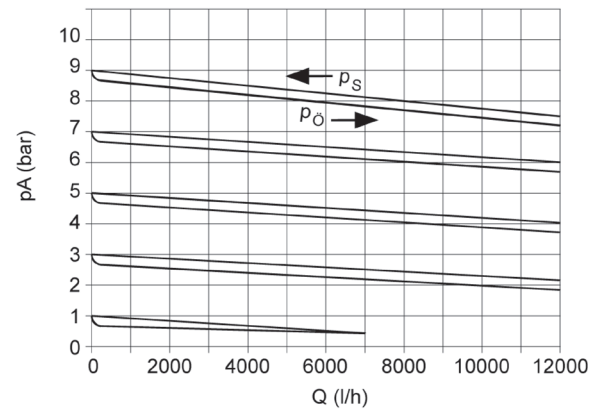

Description	
pA	Working pressure
pS	closing pressure
pO	opening pressure
Q	Flow

# Pressure Reducing Valve DMV 755

## Applications for pressure reduction valves

Example 1: secondary pressure - system dynamically flowing

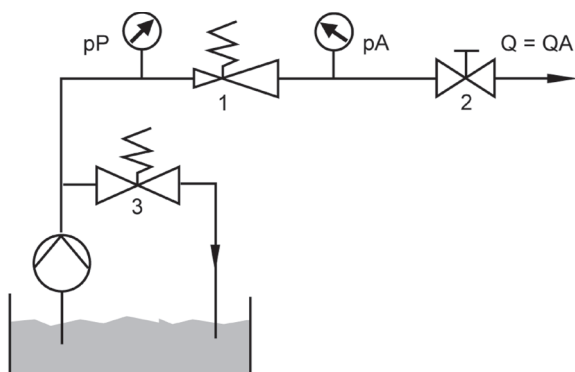

If the stop valve is closed, the working pressure pA rises by the amount of the closing pressure pS.

Example 2: secondary pressure - system closed

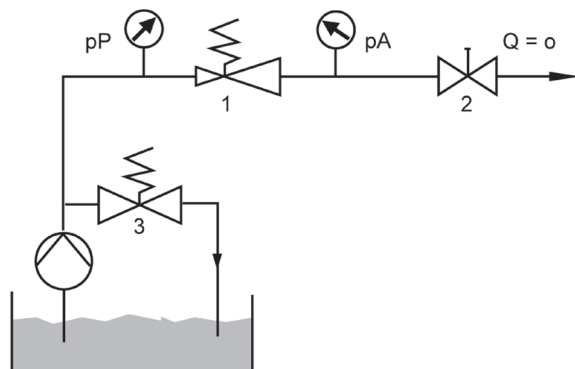

If the stop valve is opened, the working pressure pA drops by the amount of the opening pressure pÖ.

	Description
pA	Working pressure
pP	Pump pressure
Q	Flow
QA	Flow in the working point
1	Pressure reducing valve
2	Stop valve
3	Pressure relief valve

# Pressure Reducing Valve DMV 755

## Connection socket

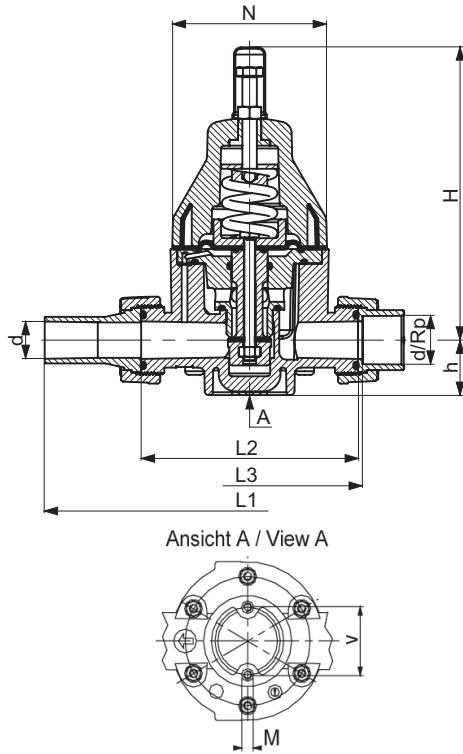

## Connection spigot

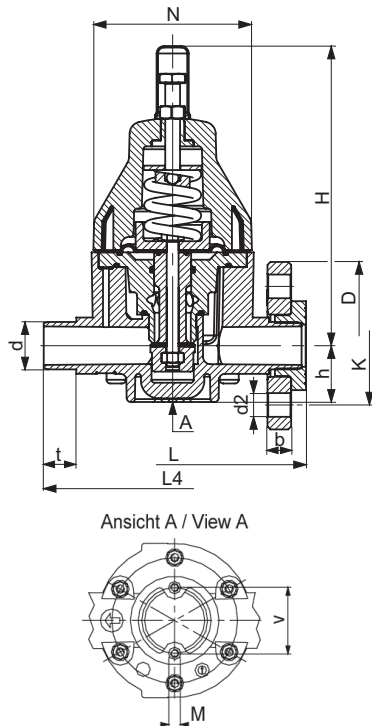

d (mm)		16	20	25	32	40	50	63	
DN (mm)		10	15	20	25	32	40	50	
DN (inch)		3/8	1/2	3/4	1	1 1/4	1 1/2	2	
valve body	Insert/flange								
b	GFR flange DIN	-	12.2	14	15	17	17	18	
	PP/st. flange DIN	-	13	14.5	15.5	17.5	17.5	19	
	PP/st. flange ANSI	-	12	12	16	16	18	18	
d2	GFR flange DIN	-	14	14	14	18	18	18	
	PP/st. flange DIN	-	14	14	14	18	18	18	
	PP/st. flange ANSI	-	16	16	16	16	16	20	
D	GFR flange DIN	-	96.5	106	115	142	152	168	
	PP/st. flange DIN	-	96	106	116	141	151	166	
	PP/st. flange ANSI	-	95	105	113	130	133	160	
G*		3/4	1	1 1/4	1 1/2	2	2 1/4	2 3/4	
h	PVC-U, PP, PVDF	25	25	38	38	56	56	56	
H	PVC-U, PP, PVDF	174	174	202	202	262	262	262	
K	GFR flange DIN	-	65	75	85	100	110	125	
	PP/st. flange DIN	-	60	70	80	89	98	121	
	PP/st. flange ANSI	-	65	75	85	100	110	125	
L		-	150	180	180	230	230	250	
L1	PVC-U	PE100 Spigot DIN	-	310	340	340	405	433	453
	PP	PP spigot	-	228	264	270	331	338	343
	PVDF	PVDF spigot	-	225	262	268	324	331	336
L2	PVDF		120	120	150	150	200	201	200
	PP, PVC-U		120	120	150	150	205	205	205
L3	PVC-U	Socket PVC-U DIN, PVC-U ANSI, BS	126	126	156	156	211	211	211
		Socket PVC-U JIS	132	128	160	159	211	211	213
		PVC-U female thread Rp	126	127.6	158	162.6	221	231	235.6
		Female thread 1.4571	130	130	161	164	221	223	223
	PP	PP socket DIN	128	126	156	156	211	211	211
		PP female thread Rp	-	126	156	156	211	213	215
PVDF	PVDF socket DIN	127	125	156	156	206	207	206	
L4		144	144	174	174	224	224	244	
M		6	6	6	6	8	8	8	
N		81	81	107	107	147	147	147	
Rp*		3/8	1/2	3/4	1	1 1/4	1 1/2	2	
t		14	16	19	22	26	31	38	
V	PP, PVC-U, PVDF	40	40	46	46	65	65	65	

all dimensions in mm / \* dimensions in inch



# Pressure Reducing Valve DMV 755

## Sectional drawing

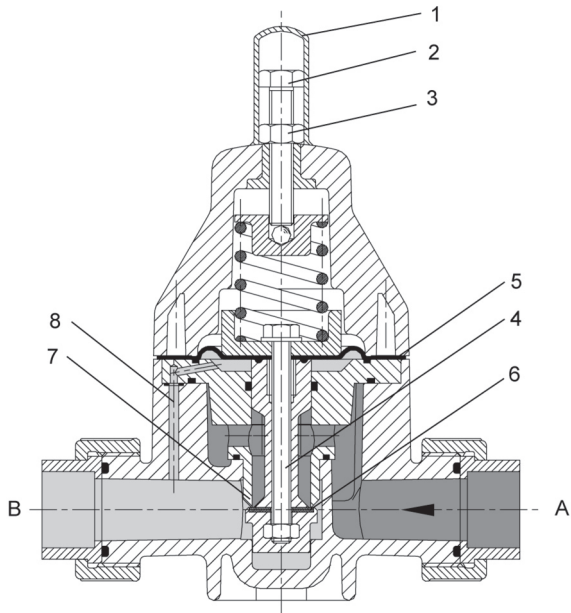

	Description
A	primary side
B	secondary side
1	Protection cap
2	adjustment screw
3	counter nut
4	piston
5	diaphragm
6	flat sealing ring
7	valve seat
8	control bore hole

# Pressure Reducing Valve DMV 755

## Components

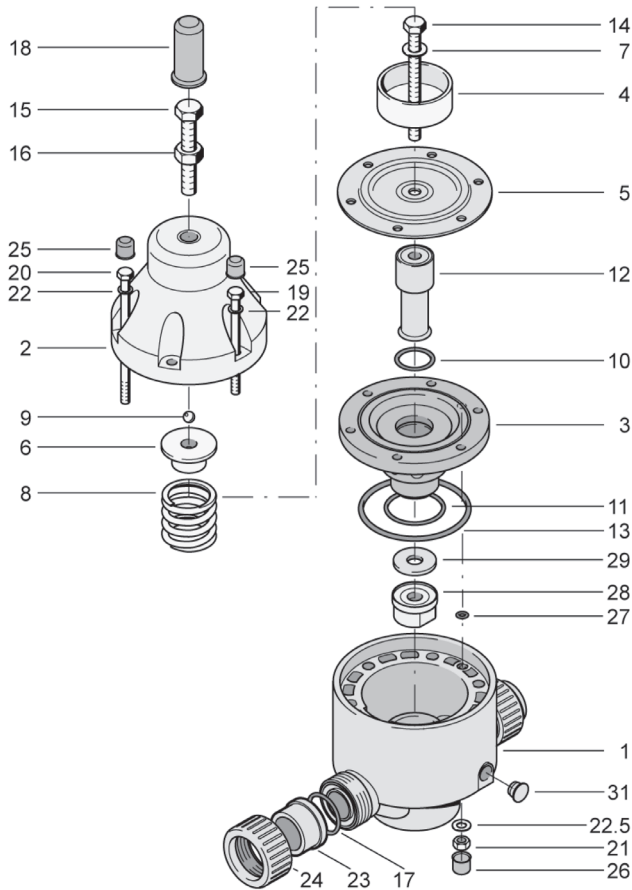

	Quantity DN 10-15	Quantity DN 20-50	Description
1	1	1	housing, complete
2	1	1	bonnet
3	1	1	separating disc
4	1	1	spring plate
5	1	1	diaphragm
6	1	1	pressure plate
7	1	1	Washer
8	1	1	pressure spring
9	1	1	steel ball
10	1	1	O-ring
11	1	1	O-ring
12	1	1	piston
13	1	1	O-ring
14	1	1	hexagon screw
15	1	1	hexagon screw
16	1	1	hexagon nut
17	2	1	O-ring
18	1	1	Protection cap
19	4	2	hexagon screw
20	-	4	hexagon screw
21	4	6	hexagon nut
22	4	6	Washer
22.5	4	6	Washer
23	2	2	Union end
24	2	2	Union nut
25	4	6	Protection cap
26	4	6	Protection cap
27	1	1	O-ring
28	1	1	piston guidance
29	1	1	flat sealing ring
31	2	2	plug